

GPIB Command Syntax

for

E1966A 1xEV-DO Terminal Test Application Revision A.07

E1976A 1xEV-DO Rel 0 FTM Test Application Revision A.01

E6706A 1xEV-DO Lab Application Revision A.04

E6706T Special High Data Rate 1xEV-DO Lab Application T.01

Print Date: December 2006

1000-1931

www.agilent.com/find/E1966A

www.agilent.com/find/E1976A

www.agilent.com/find/E6706A

www.agilent.com/find/E6706T



Agilent Technologies

NOTE: *This guide is applicable to the E6706T, however there are a few exceptions which can be found in the Online User's Guide available at <http://wireless.agilent.com/rfcomms/refdocs/1xevdo/default.php>*

Notice

Information contained in this document is subject to change without notice.

All Rights Reserved. Reproduction, adaptation, or translation without prior written permission is prohibited, except as allowed under the copyright laws.

This material may be reproduced by or for the U.S. Government pursuant to the Copyright License under the clause at DFARS 52.227-7013 (APR 1988).

Agilent Technologies, Inc.
Learning Products Department
24001 E. Mission
Liberty Lake, WA 99019-9599
U.S.A.

Contents

Diagram Conventions	6
ABORt	9
AFGenerator	10
CALibration	11
CALCulate:SMONitor	12
CALL:APARameter	13
CALL:APPLication	14
CALL:AWGNoise	16
CALL:BAND	16
CALL:CCHannel	17
CALL:CCODE	17
CALL:CHANnel	17
CALL:CLPControl	18
CALL:CONNected	18
CALL:CONTRol	18
CALL:COUNt	19
CALL:COUNt:DTMonitor	23
CALL:CSTime	24
CALL:DATA	25
CALL:DCONnected	27
CALL:DORMant	27
CALL:FUNCTion:DATA	27
CALL:HANDoff	27
CALL:IDLE:DATA?	28
CALL:MACCHannel	28
CALL:MCCode	28
CALL:MS	29
CALL:OPERating:MODE	32
CALL:PARAmeter:SECTOR	32
CALL:PLOGging	32
CALL:PNOFfset	33
CALL:POWER	33
CALL:PROTocol	33
CALL:RFGenerator	34
CALL:SCLOSE	34
CALL:SETup	34
CALL:SOPen?	35
CALL:STATus	36
CALL:TEST856	38
CALL:TOTAL:POWER	39
CALL:TRIGger	39
CALL:WAVEform	39

Contents

DISPlay	40
FETCh:AFANalyzer	41
FETCh:CAPPower	43
FETCh:CPErRor	43
FETCh:CFDTune	43
FETCh:CPOWer	44
FETCh:CTDPower	44
FETCh:CTXSpurious	44
FETCh:DAPower	45
FETCh:DOWQuality	45
FETCh:GAPPower	49
FETCh:SAUDio	50
FETCh:SMONitor	52
FETCh:TROPower	52
INITiate	53
READ	55
RFANalyzer	57
RFGenerator:OUTPut	58
SETup:CONTinuous	59
SETup:AFANalyzer	59
SETup:CAPPower	61
SETup:CFDTune	62
SETup:CPErRor	64
SETup:CPOWer	65
SETup:CTDPower	66
SETup:CTXSpurious	67
SETup:DAPower	68
SETup:DOWQuality	69
SETup:GAPPower	70
SETup:SAUDio	71
SETup:SMONitor	73
SETup:TROPower	75
STATus:OPERation	75
STATus:PRESet	76
STATus:QUEStionable	76
Status Byte Register	77
Standard Event Status Register	77
SYSTem:APPLication	78
SYSTem:AUDio	79
SYSTem:BEEPer	79
SYSTem:COMMunicate	79
SYSTem:CONFigure	80

Contents

SYSTem:CORRection	80
SYSTem:CURRent:TA	80
SYSTem:DATE	81
SYSTem:ERRor?	81
SYSTem:FATal	81
SYSTem:INSTRument	81
SYSTem:MEASurement:RESet	81
SYSTem:PRESet	81
SYSTem:REGister	82
SYSTem:ROSCillator	82
SYSTem:SYNChronized	82
SYSTem:STATus	82
SYSTem:TIME	82
SYSTem:TZONE	83
SYSTem:UTC	83
IEEE 488.2 Common Commands	83

GPIB Syntax for E1966A, E1976A and E6706A/T

Diagram Conventions

Description

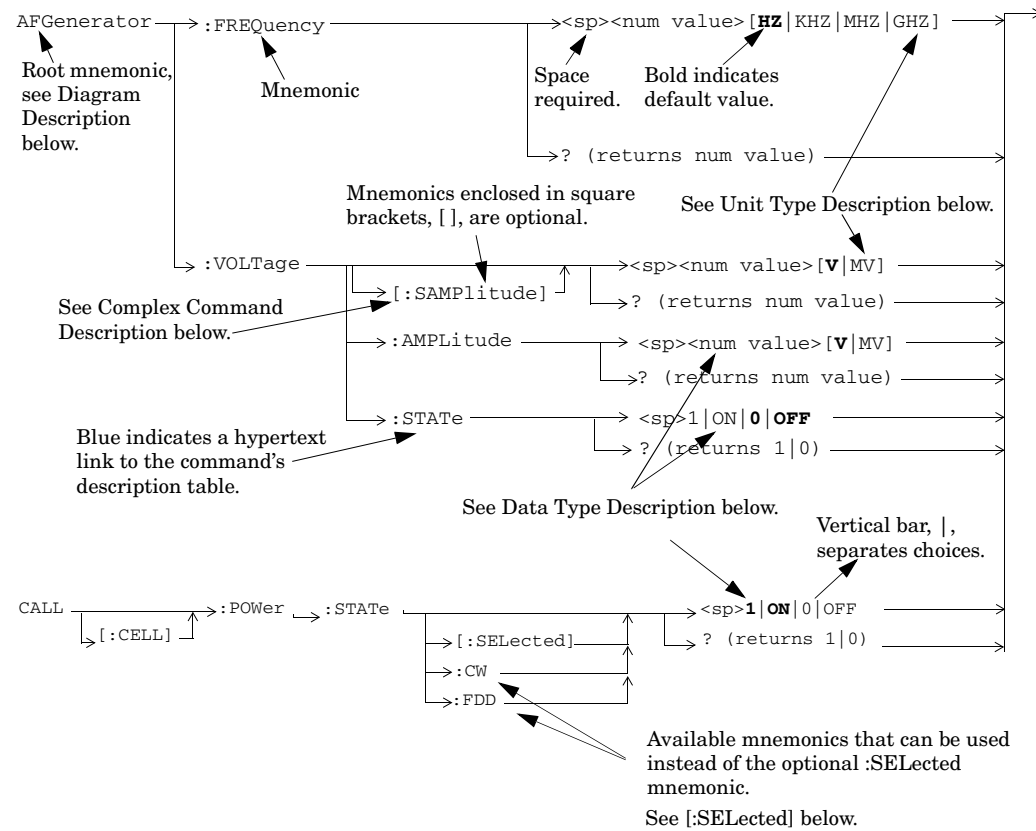

Diagram Description

Mnemonics are connected by lines. Each line can be followed in only one direction, as indicated by the arrow at the end of the line. Any combination of mnemonics that can be generated by starting at the root mnemonic and following the line in the direction of the arrow is syntactically correct.

GPIB Syntax for E1966A, E1976A and E6706A/T

The uppercase letters of a mnemonic represent the short form of the mnemonic, whereas the long form of a mnemonic is the short form followed by the lowercase letters. The test set accepts either the long form or the short form of the mnemonic. The mnemonics that are inside square brackets are optional. That is, a command operates the same whether or not the mnemonic in square brackets is used in the command.

The drawings show the proper use of spaces. Where spaces are required they are indicated by <sp>, otherwise no spaces are allowed between mnemonics.

Complex Command Description

Complex commands are valuable because they set the state of the parameter and a value for that parameter. For example, the command in the above figure that contains the mnemonic [:SAMPLitude] is a complex command because sets the state to ON as well as the amplitude. You can use parameters such as amplitude, frequency, gain, number, time, and value as a complex command. Refer to the specific command for the parameter that applies.

Data Type Description

num value	Integer, float or scientific values. For example, CALL:POWer -55.5 CALL:POWer -5.55E+001 CALL:CHANnel 525
string	Characters. The string will often need to be enclosed in single or double quotes, depending upon your programming environment. For example, CALL:UPLink:PRACHannel:ASUBchannels '111111111111' The string returned by the test set is enclosed by double quotes.
choice1 choice2 choice3	Specific character choices. For example, CALL:OPERating:MODE D2KTest SYSTem:COMMunicate:GPIB:DEBug ON

Unit Type Description

Some commands have optional units of measurement. These are displayed in square brackets. If no units are specified in the command then the default unit in bold font is used. The test set accepts the specified unit either with or without a space inserted between the <num value> and the unit (for example, both 10S and 10 S are valid). The following table summarizes the units available.

Description	Optional Units	Example
-------------	----------------	---------

GPIO Syntax for E1966A, E1976A and E6706A/T

Amplitude (linear)	V MV	To set the spectrum monitor's timeout interval to 20 seconds, use any of the following formats: SETup:SMONitor:TIMEout:TIME 20 SETup:SMONitor:TIMEout:TIME 20S SETup:SMONitor:TIMEout:TIME 20 S
Power (logarithmic)	DBM DBW	
Level (relative)	DB	
Frequency	HZ KHZ MHZ GHZ	
Time	S MS US NS	
Percentage	PCT	

[:SElected] Mnemonic

The [:SElected] Mnemonic is an optional mnemonic that implies a current selection on the test set. Often there are other mnemonics that can be used in place of the [:SElected] mnemonic to configure a setting that is not the currently selected configuration on the test set. The mnemonics that can replace the [:SElected] mnemonic are listed in parentheses separated by vertical bars (|) in the description table title. An example of a command that contains the [:SElected] mnemonic is shown in the following table.

CALL[:CELL]:POWER:AMPLitude[:SElected]		Available mnemonics that can be use instead of the optional [:SElected] mnemonic.
CALL[:CELL]:POWER:AMPLitude:(CW FDD) ←		
Function	Sets/queries the desired cell power level. (See "Cell Pow information about desired versus current power levels.) The optional [:SElected] keyword in this command spec queried applies to the current system type (see "CALL[:C settings for the CW operating mode are independent of operating modes.	
Setting	Range: (This is the range of settings accepted, see "Cell I Ranges" for the actual hardware range of the source <ul style="list-style-type: none"> FDD: -165 dBm/3.84MHz to +37 dBm/3.84MHz CW: -177 dBm to +40 dBm 	

ABORt

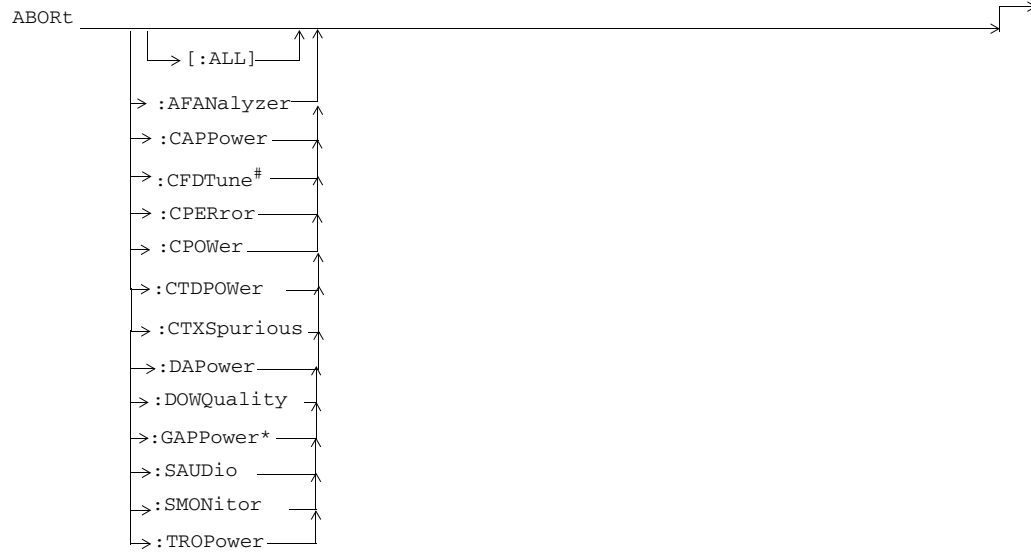

Only applicable to the lab application or feature-licensed test application.

* Only applicable to the lab application.

GPIB Syntax for E1966A, E1976A and E6706A/T

AFGenerator

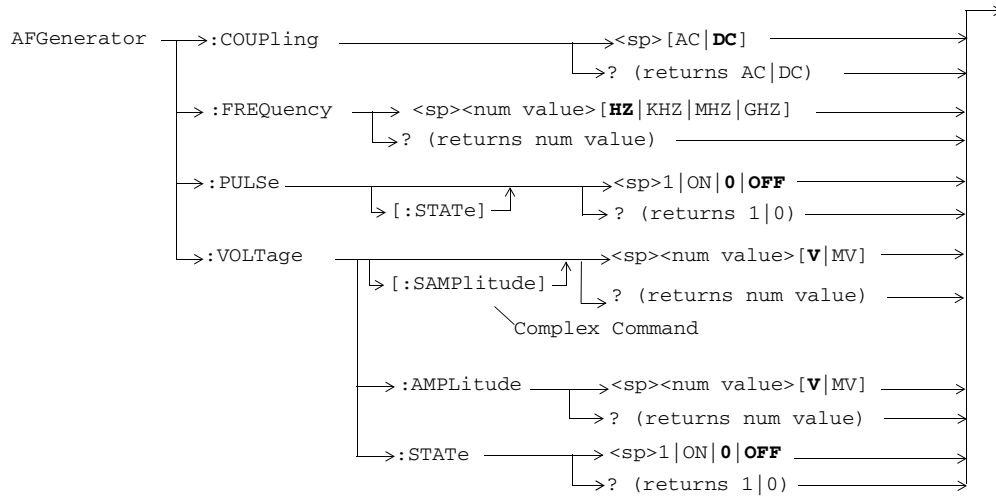

CALibration

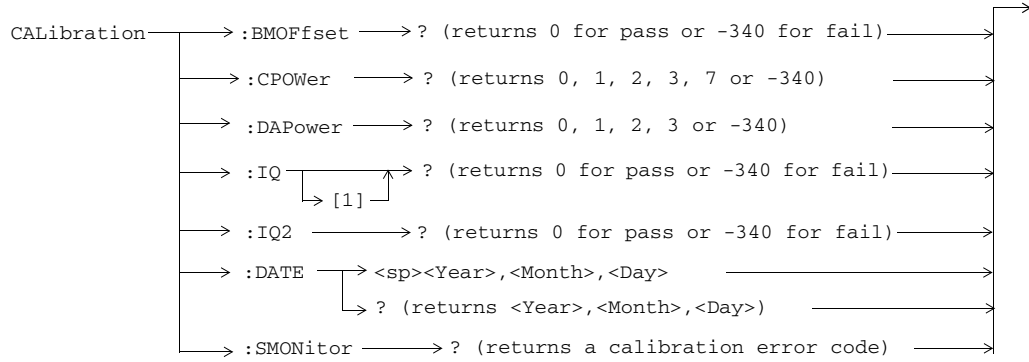

GPIB Syntax for E1966A, E1976A and E6706A/T

CALCulate:SMONitor

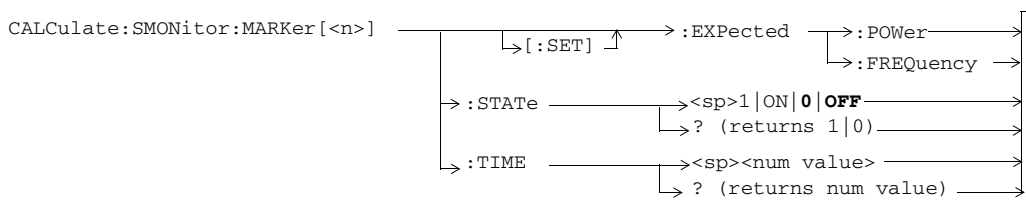
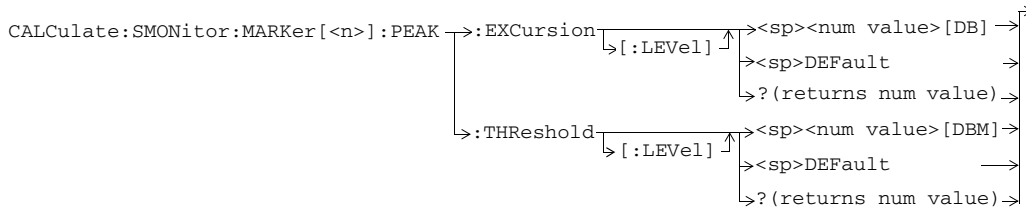
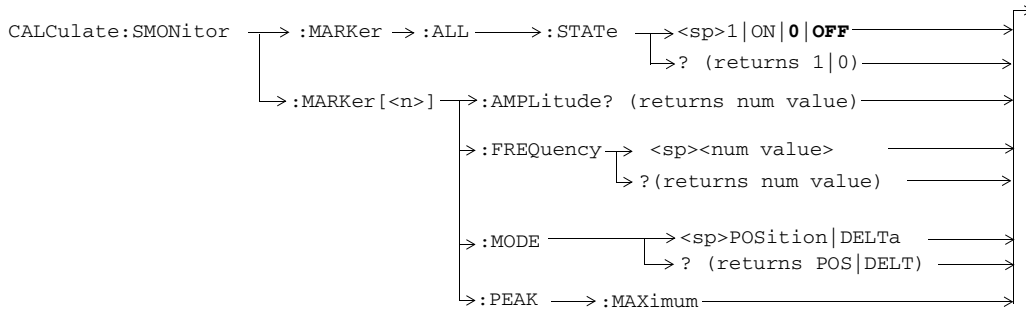

CALL:APARAmeter

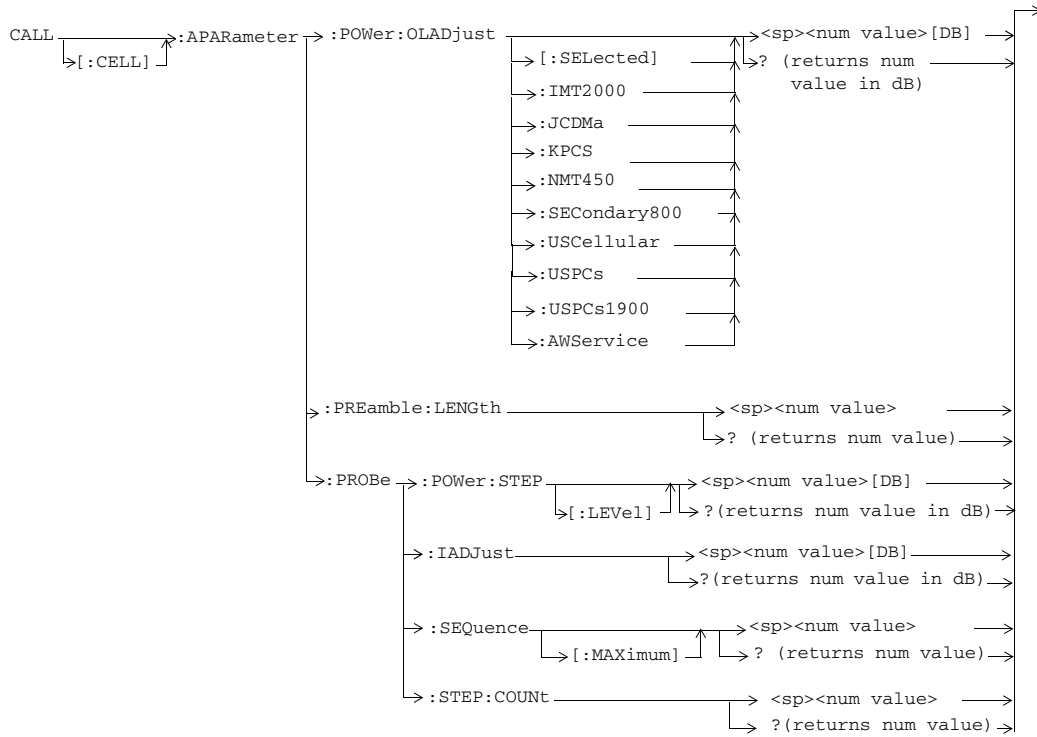

GPIB Syntax for E1966A, E1976A and E6706A/T

CALL:APPLICATION

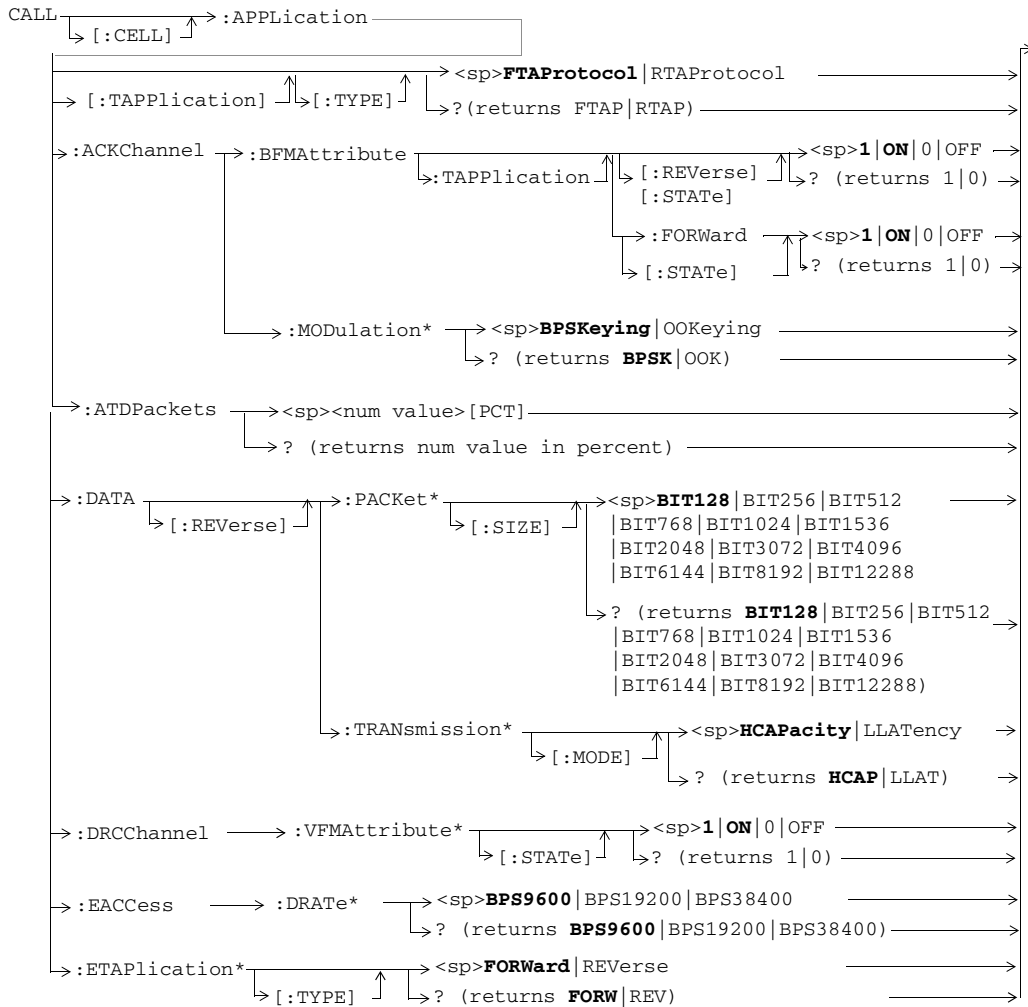

** Only applicable to the lab application and feature-licensed test application.*

GPiB Syntax for E1966A, E1976A and E6706A/T

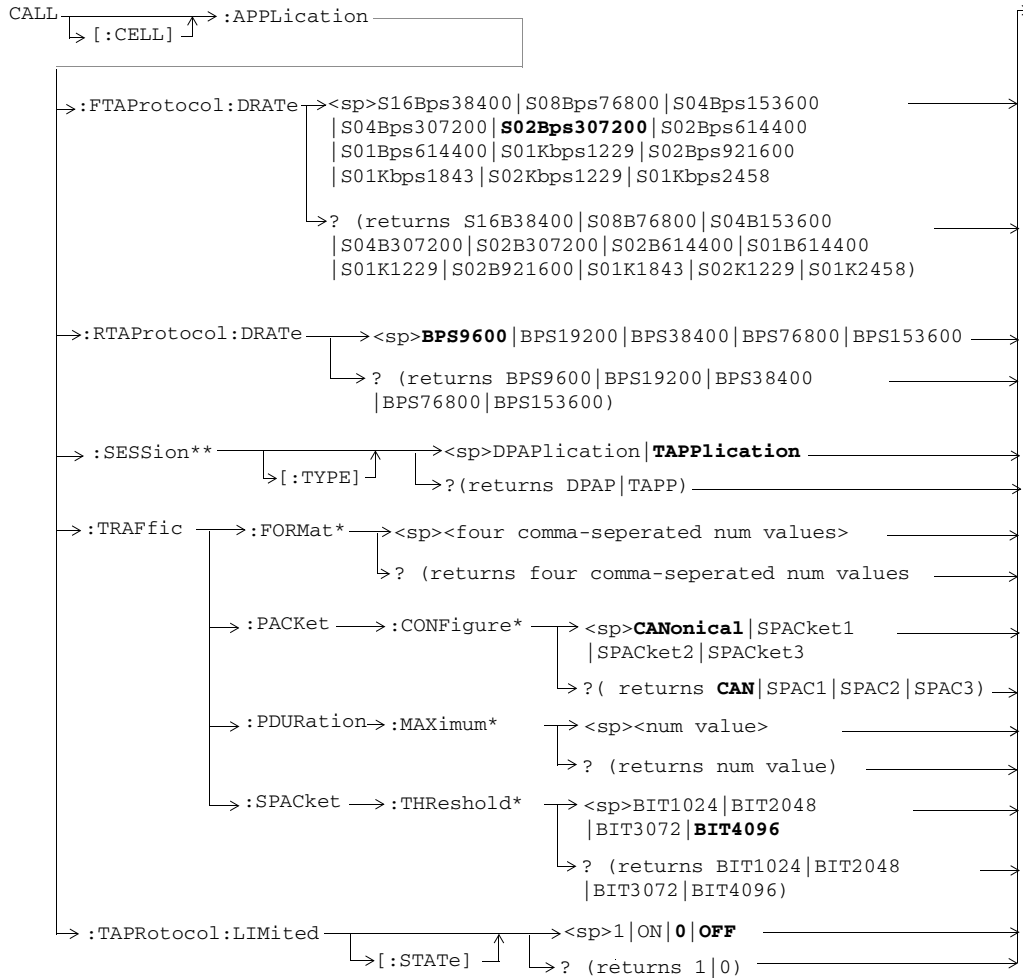

* Only applicable to the lab application and feature-licensed test application.

** Only applicable to the lab application.

GPIO Syntax for E1966A, E1976A and E6706A/T

CALL:AWGNoise

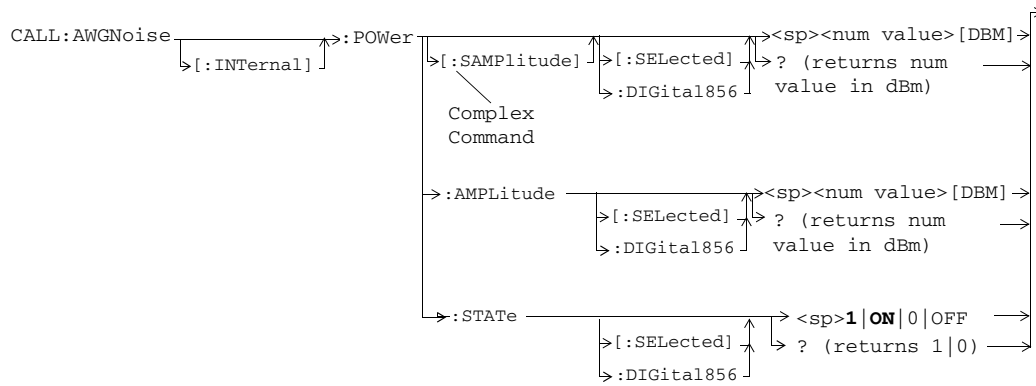

CALL:BAND

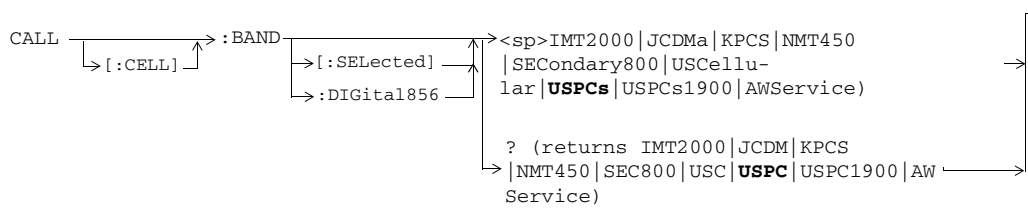

CALL:CCHannel

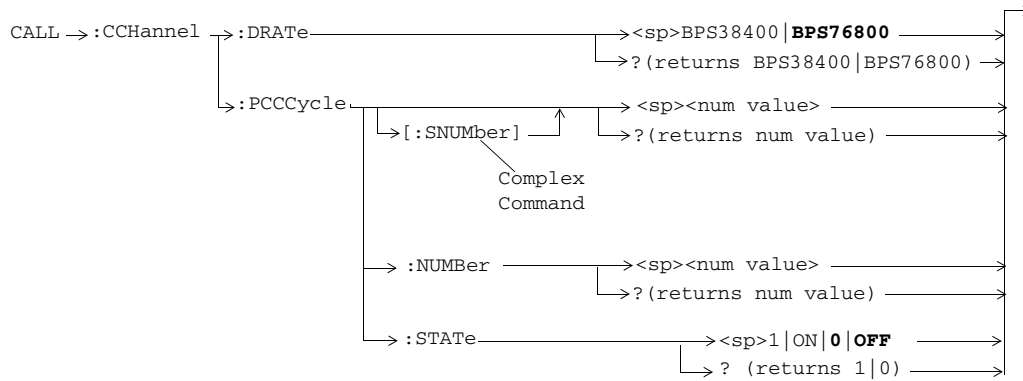

CALL:CCODE



CALL:CHANnel

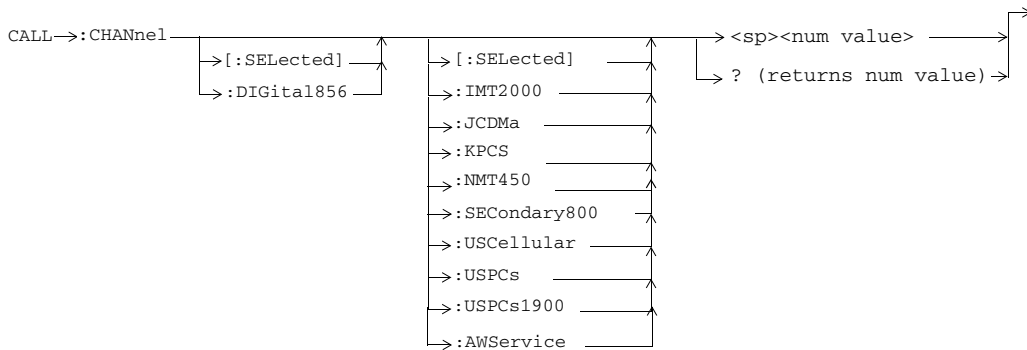

GPIO Syntax for E1966A, E1976A and E6706A/T

CALL:CLPControl

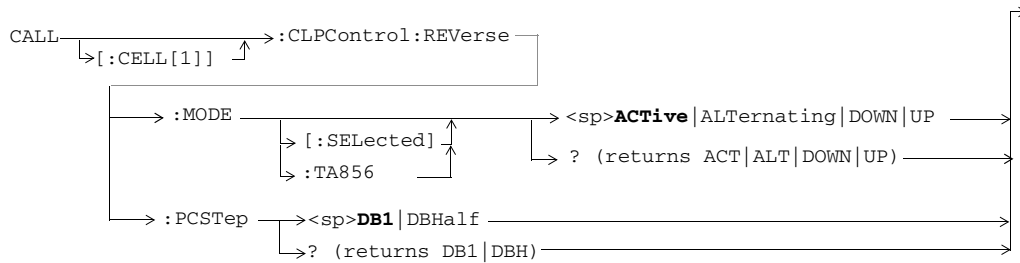

CALL:CONNected

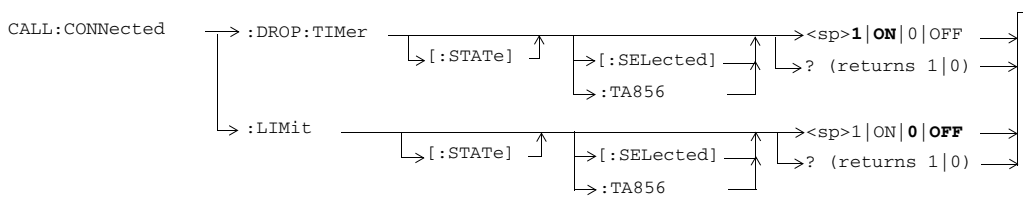

CALL:CONTRol

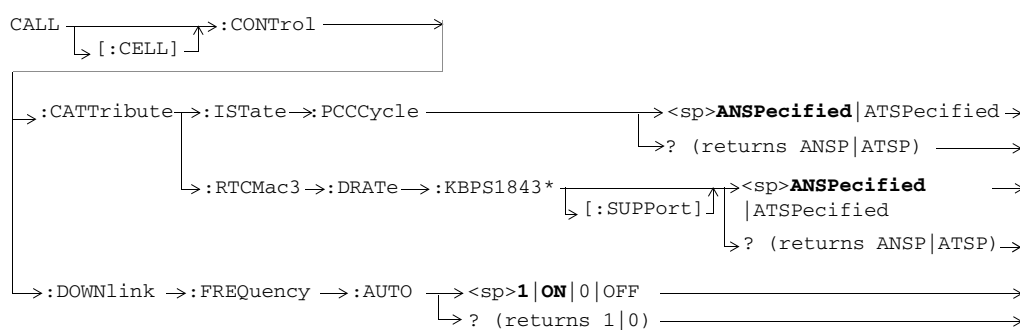

* Only applicable to the lab application and feature-licensed test application.

CALL:COUNT

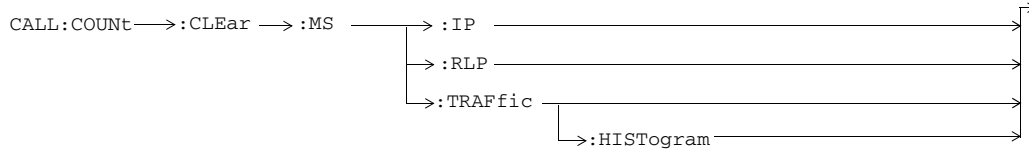

All of the commands shown in this diagram are only applicable to the lab application.

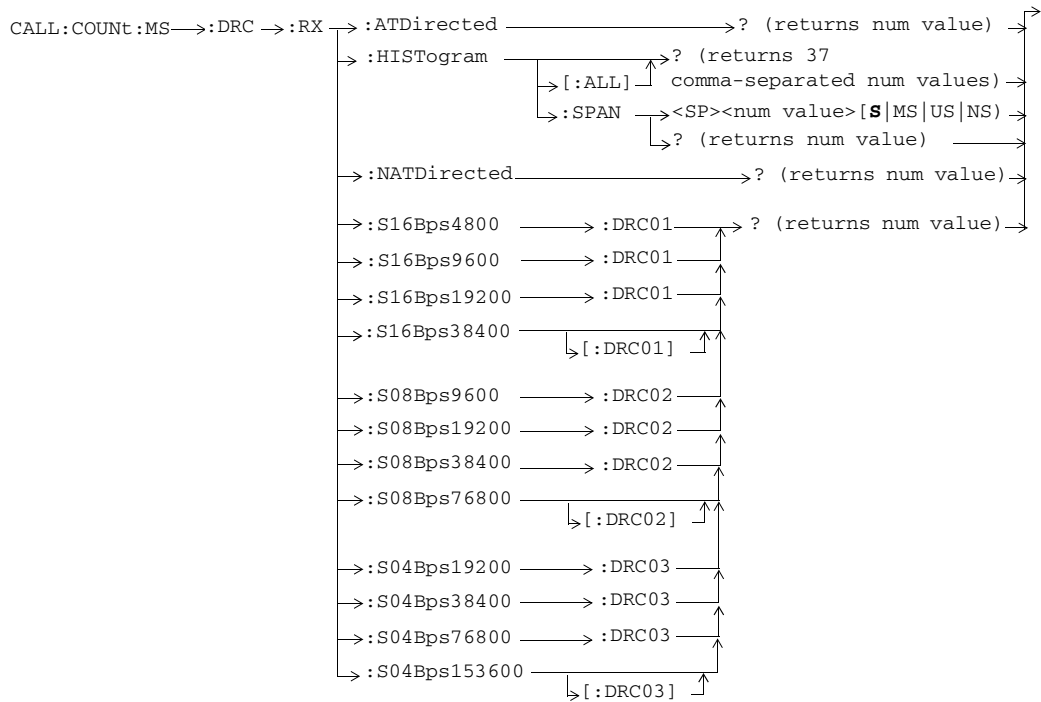

All of the commands shown in this diagram are only applicable to the lab application.

GPIB Syntax for E1966A, E1976A and E6706A/T

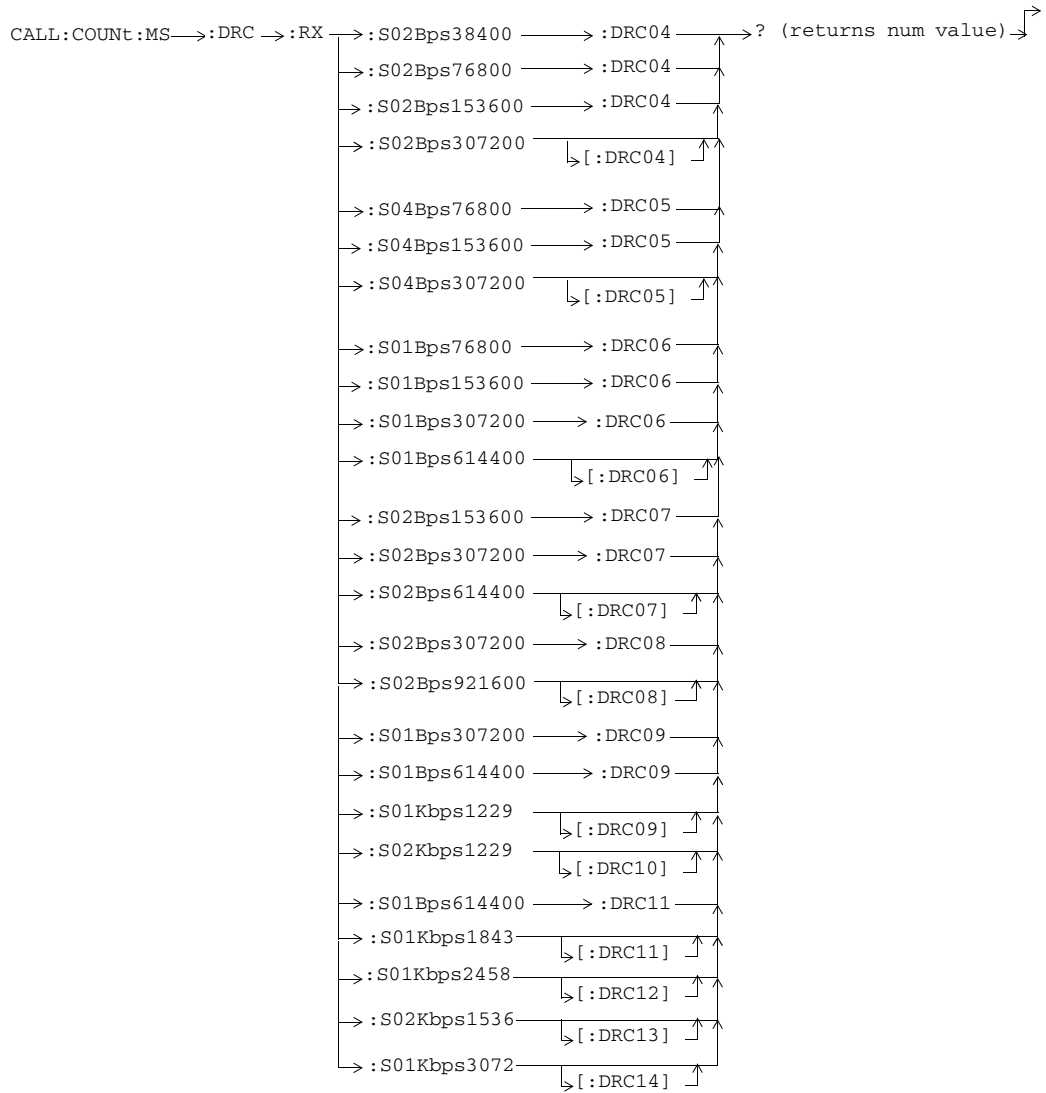

All of the commands shown in this diagram are only applicable to the lab application.

GPIB Syntax for E1966A, E1976A and E6706A/T

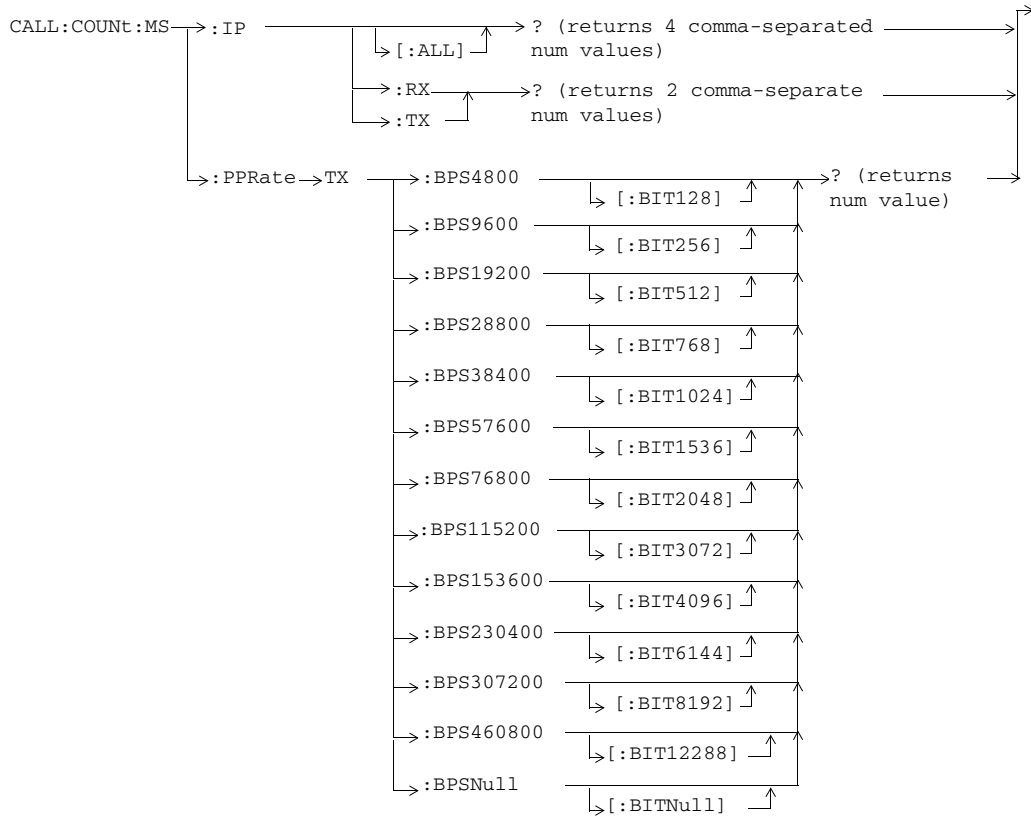

All of the commands shown in this diagram are only applicable to the lab application.

GPIB Syntax for E1966A, E1976A and E6706A/T

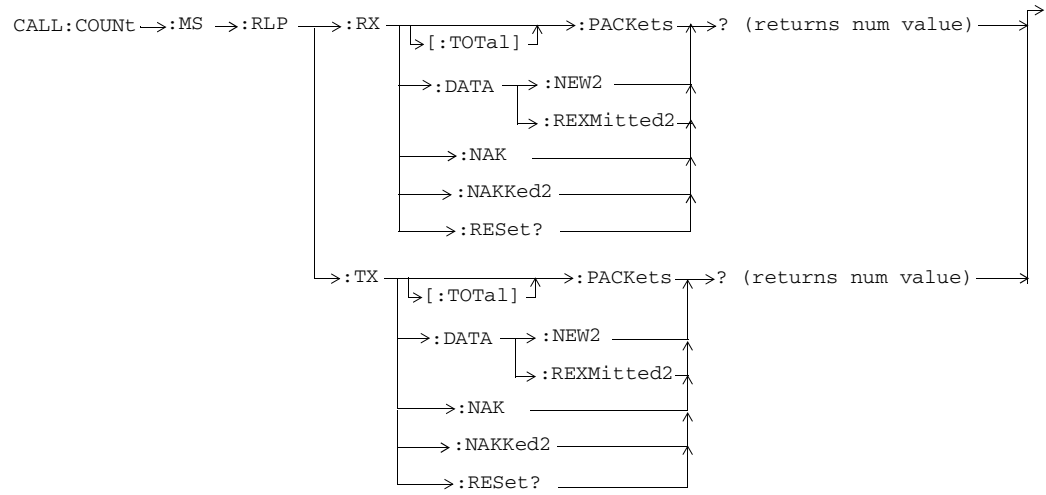

All of the commands shown in this diagram are only applicable to the lab application.

CALL:COUNT:DTMonitor

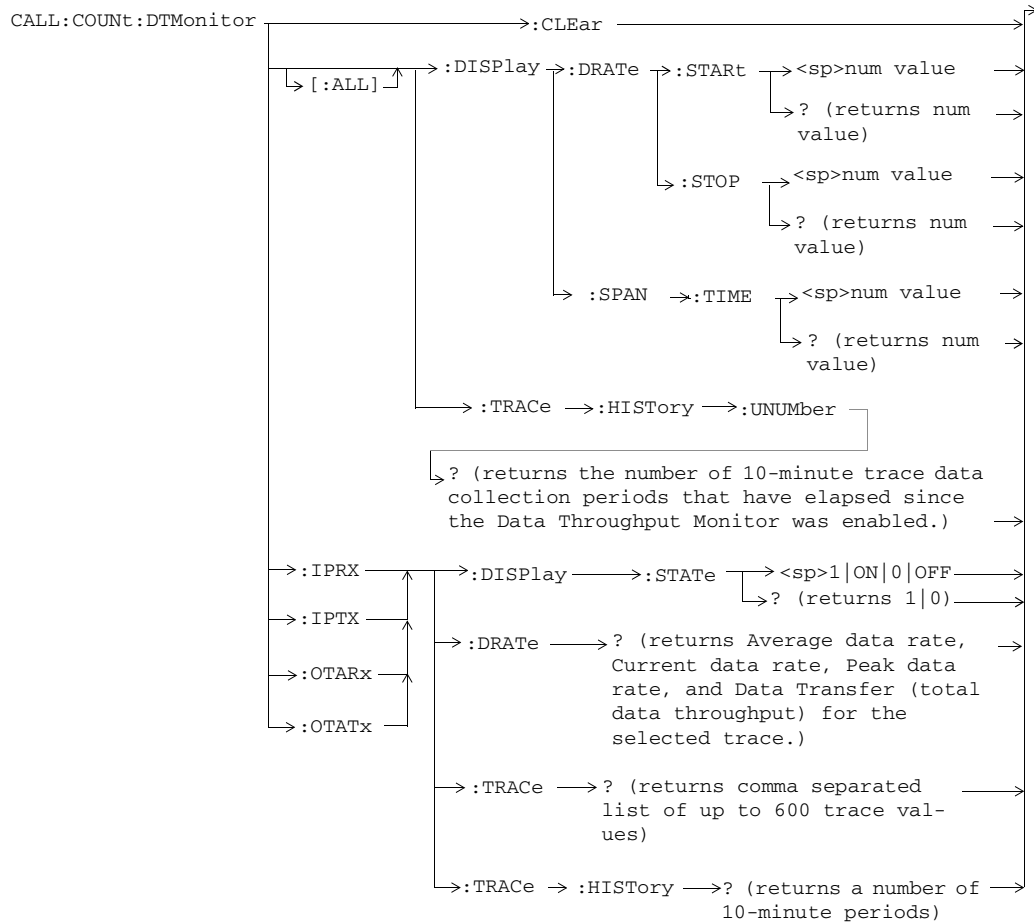

All commands shown in this diagram are only applicable to the lab application.

GPiB Syntax for E1966A, E1976A and E6706A/T

CALL:CSTime

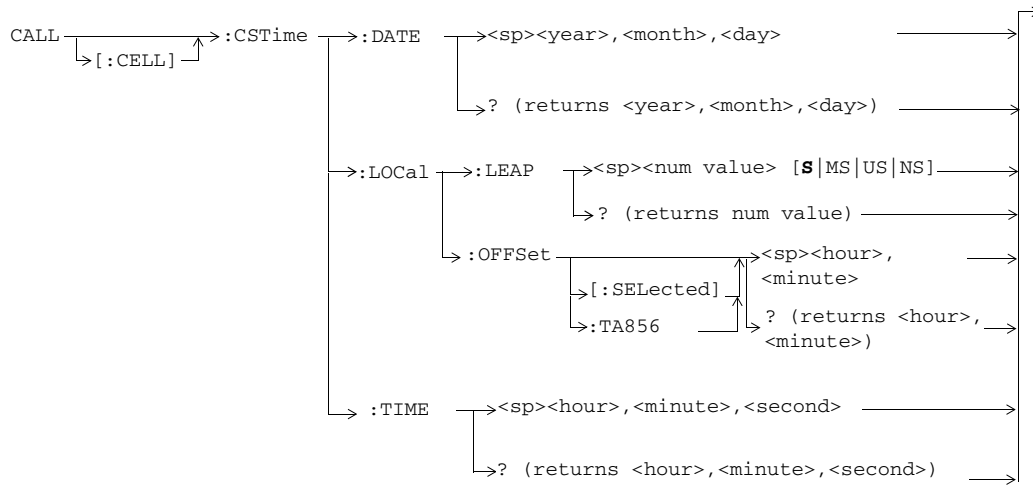

CALL:DATA

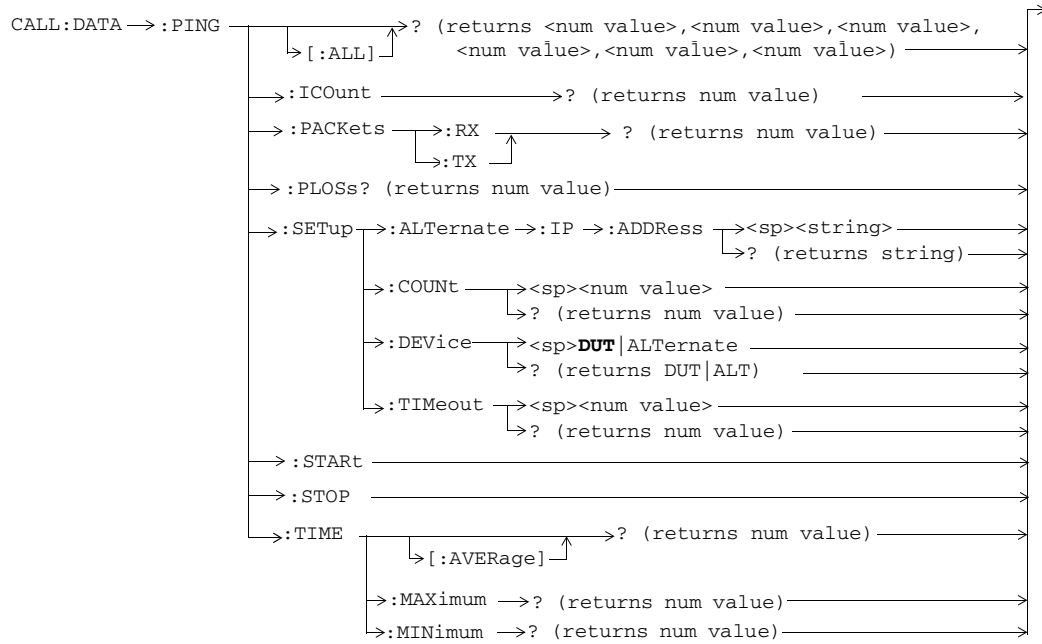

All commands shown in this diagram are only applicable to the lab application.

GPIB Syntax for E1966A, E1976A and E6706A/T

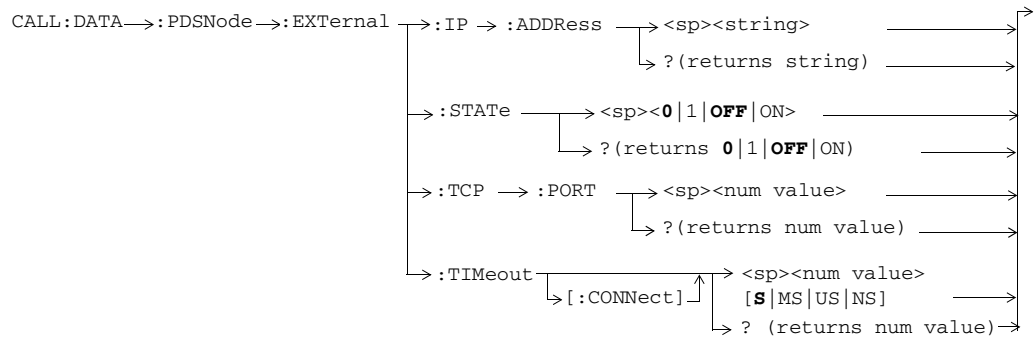

All commands shown in this diagram are only applicable to the lab application.

CALL:DCONnected

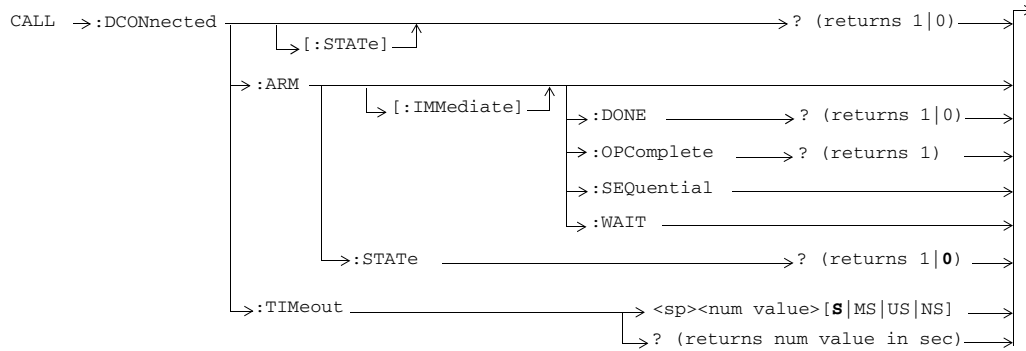

CALL:DORMant*

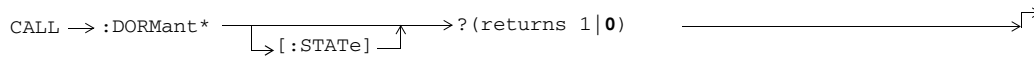

* This command is only applicable to the lab application.

CALL:FUNcTION:DATA

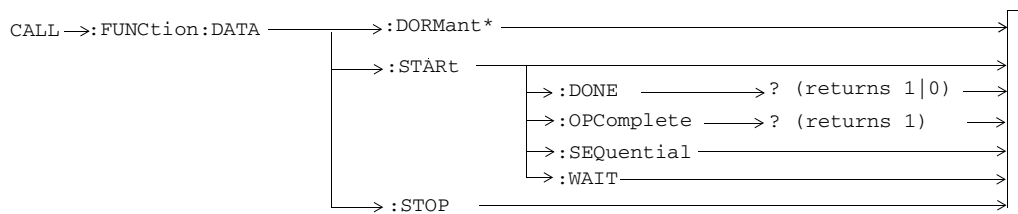

* This command is only applicable to the lab application.

CALL:HANDoff

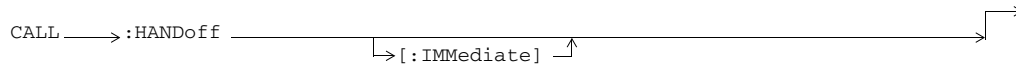

GPIB Syntax for E1966A, E1976A and E6706A/T

CALL:IDLE:DATA?

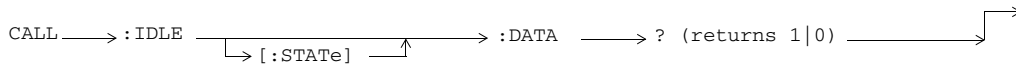

CALL:MACChannel

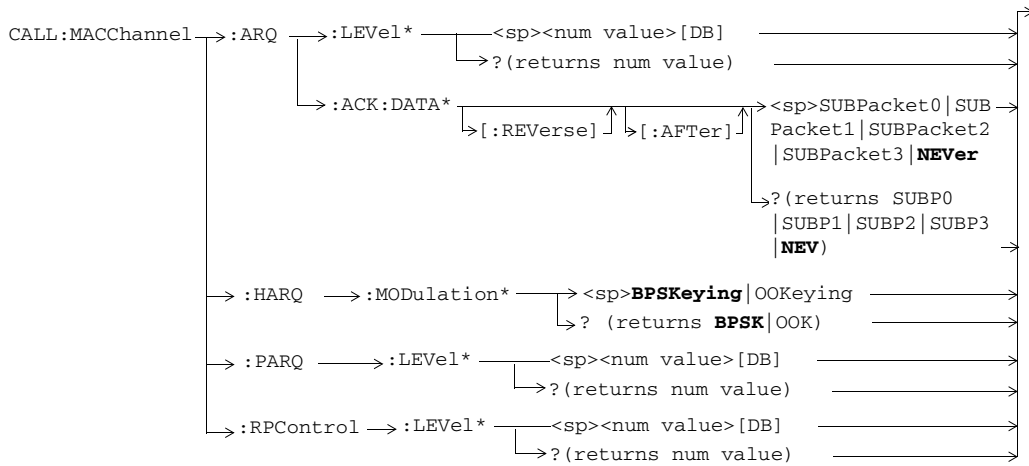

** Only applicable to the lab application and feature-licensed test application.*

CALL:MCCode

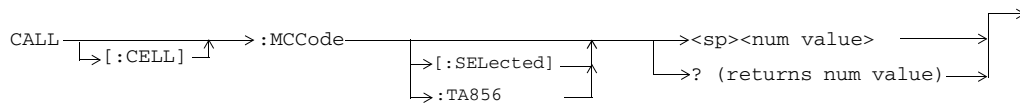

CALL:MS

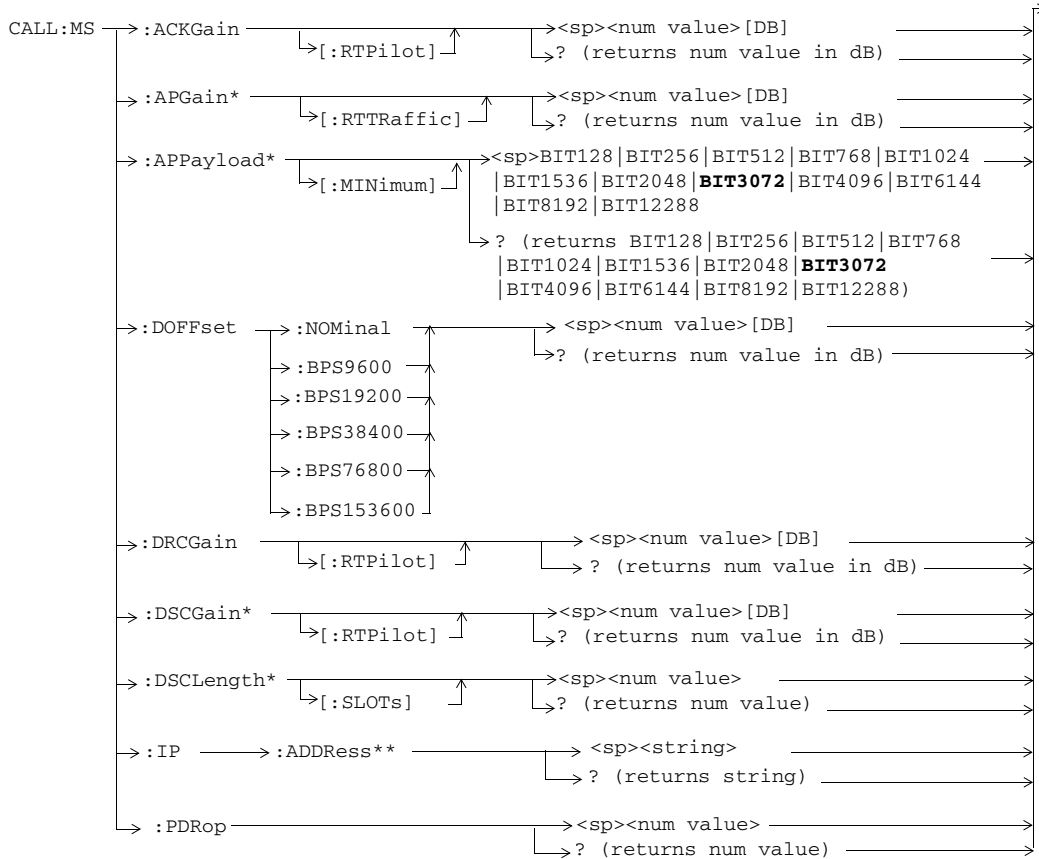

* Only applicable to the lab application and feature-licensed test application.

** Only applicable to the lab application.

GPIO Syntax for E1966A, E1976A and E6706A/T

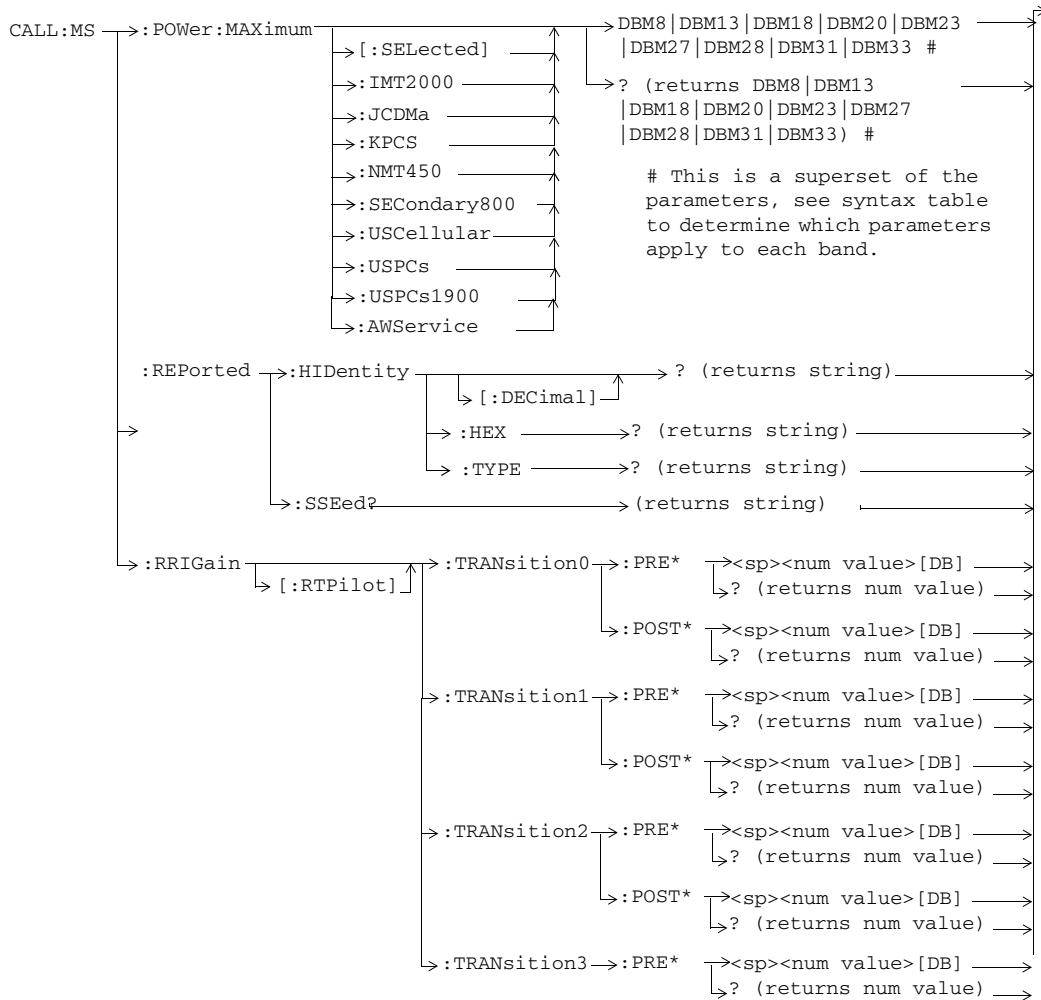

* Only applicable to the lab application and feature-licensed test application.

GPIB Syntax for E1966A, E1976A and E6706A/T

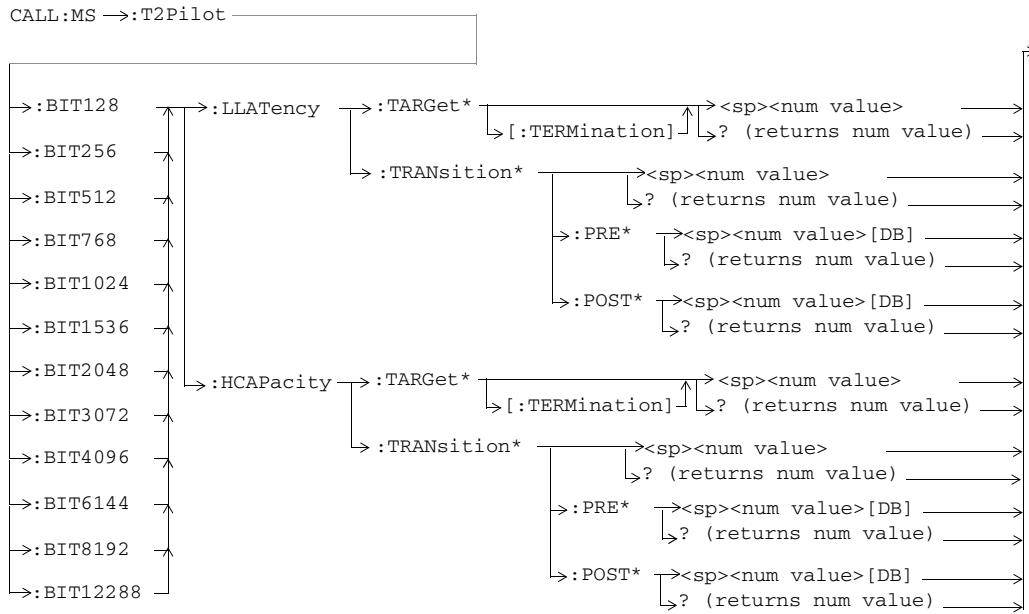

** Only applicable to the lab application and feature-licensed test application.*

GPIB Syntax for E1966A, E1976A and E6706A/T

CALL:OPERating:MODE

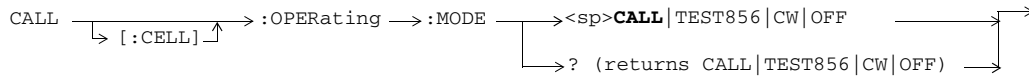

CALL:PARAMeter:SECTor

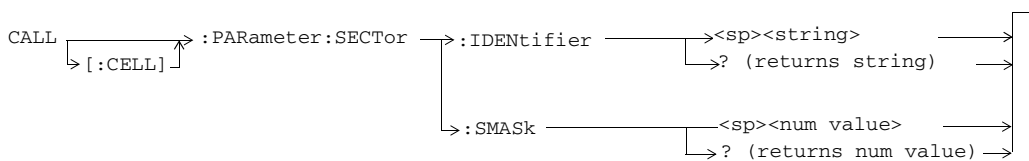

CALL:PLOGging

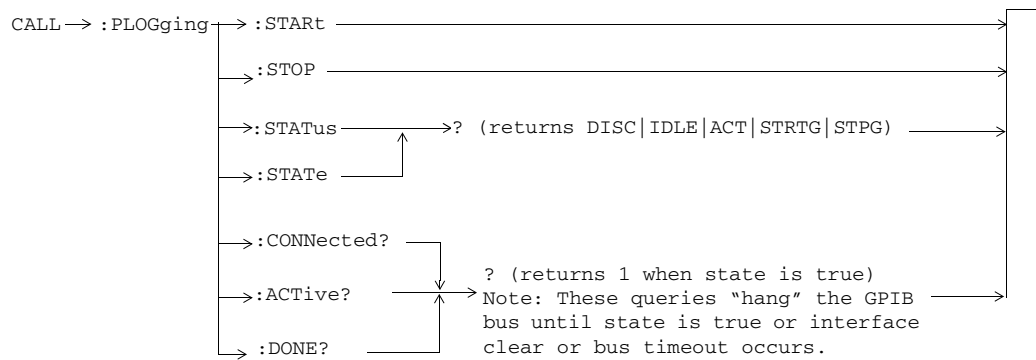

All commands shown in this diagram are only applicable to the lab application.

CALL:PNOffset

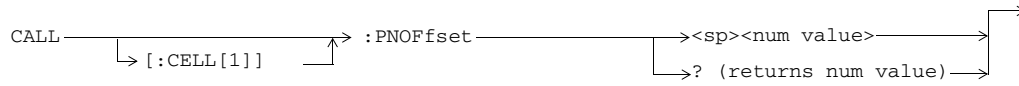

CALL:POWer

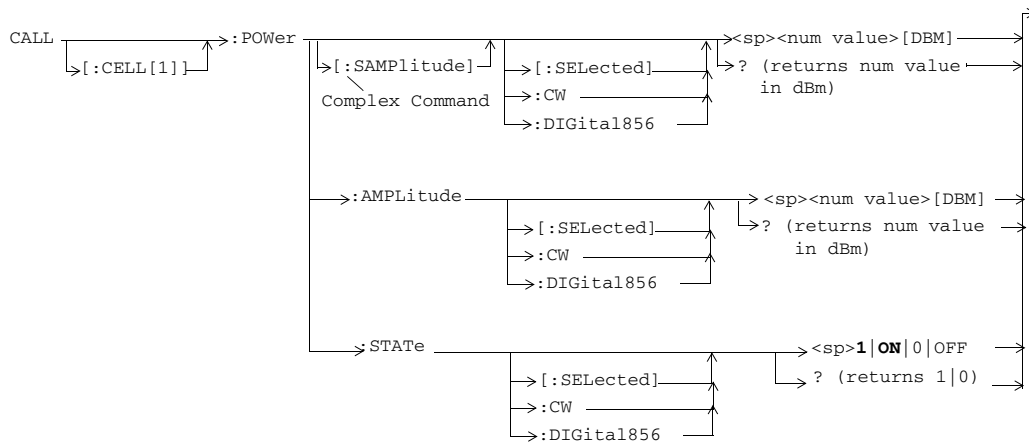

CALL:PROTOcol

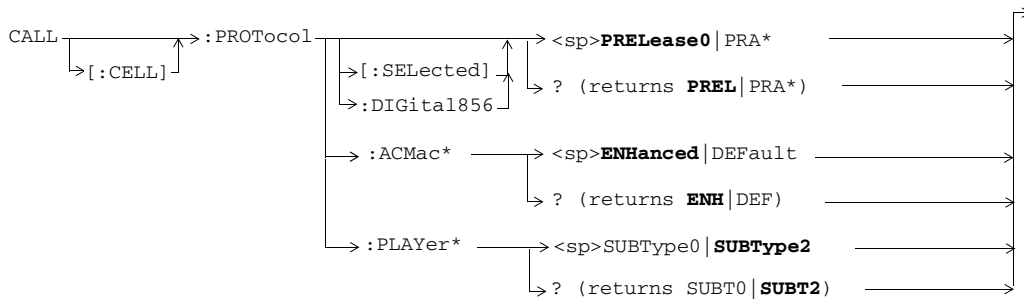

** Only applicable to the lab application and feature-licensed test application.*

GPIO Syntax for E1966A, E1976A and E6706A/T

CALL:RFGenerator

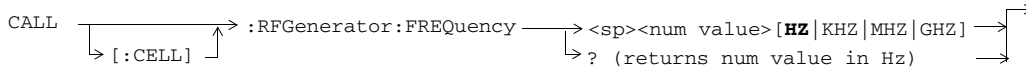

CALL:SClose

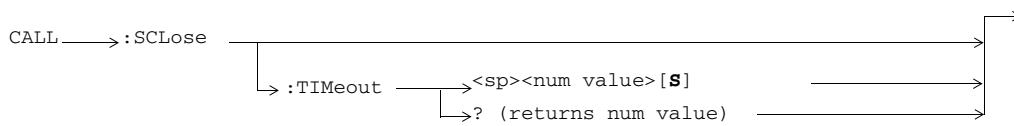

CALL:SETup

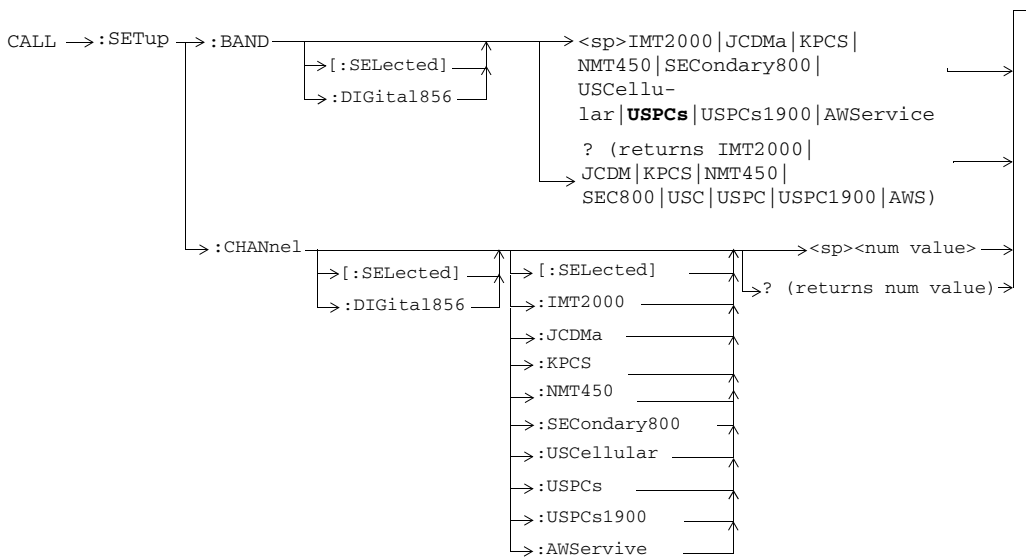

CALL:SOPen?

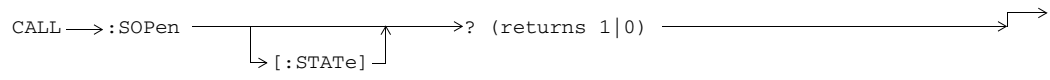

GPIB Syntax for E1966A, E1976A and E6706A/T

CALL:STATus

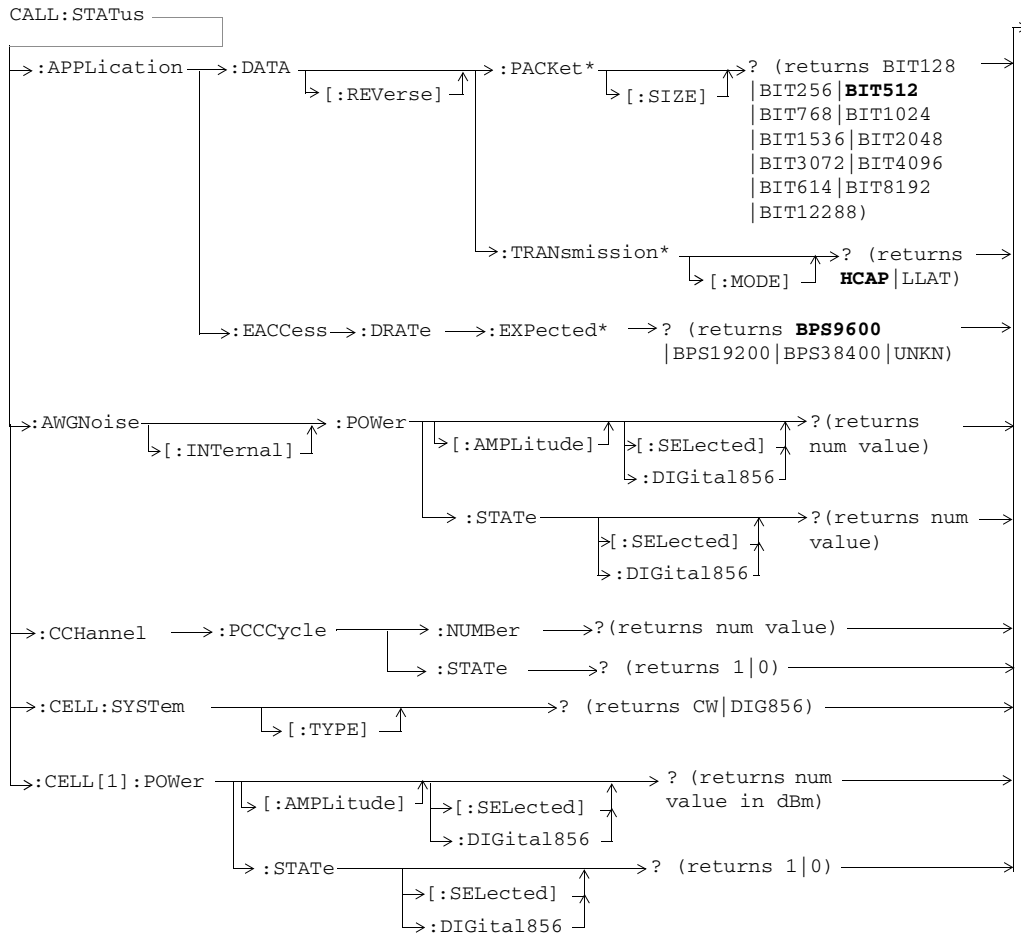

** Only applicable to the lab application and feature-licensed test application.*

GPIB Syntax for E1966A, E1976A and E6706A/T

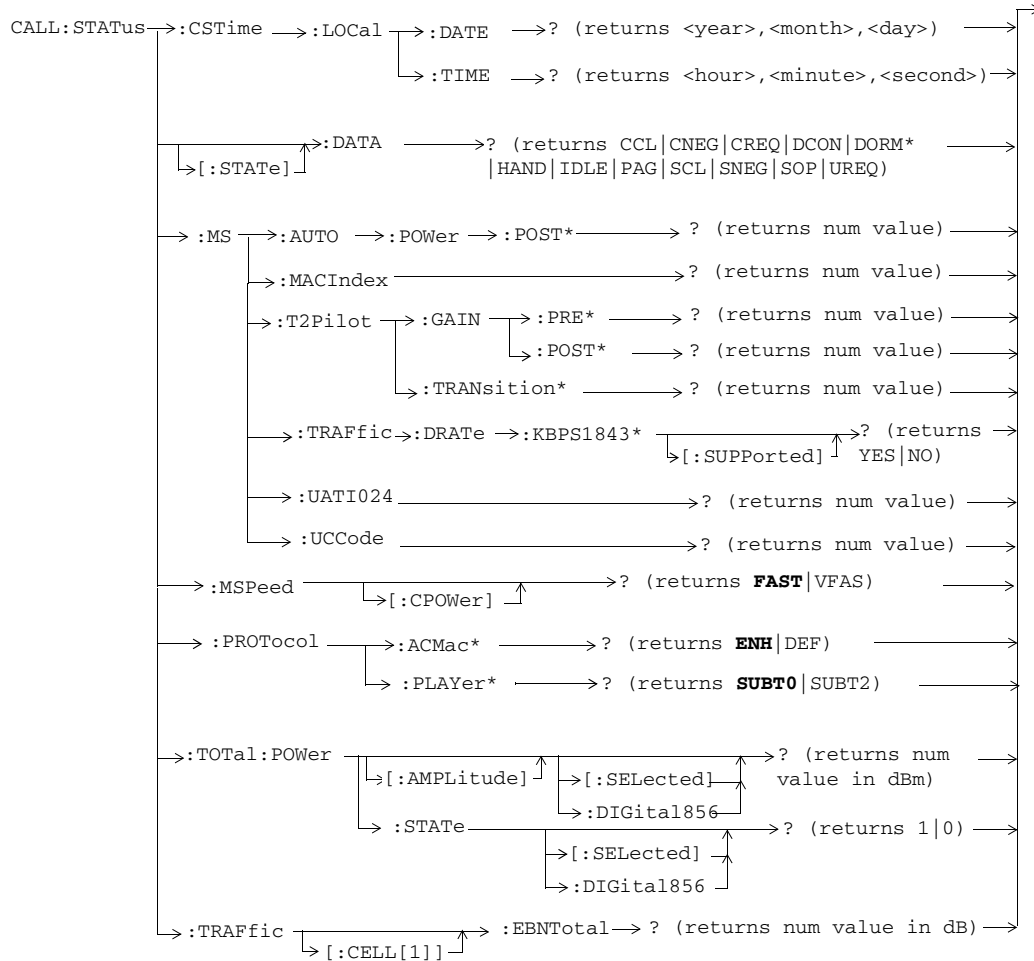

** Only applicable to the lab application and feature-licensed test application.*

GPiB Syntax for E1966A, E1976A and E6706A/T

CALL:TEST856



CALL:TOTal:POWer

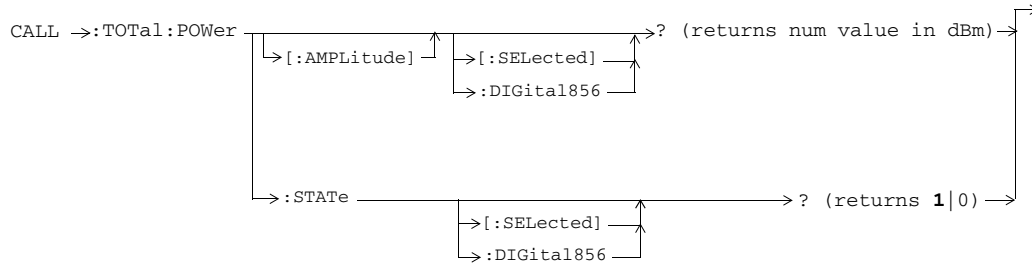

CALL:TRIGger

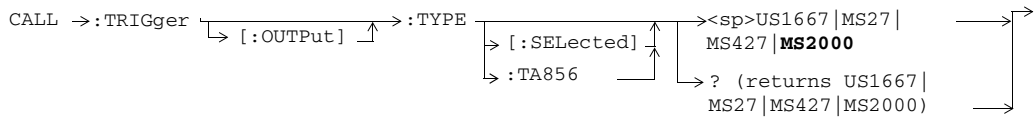

CALL:WAVeform

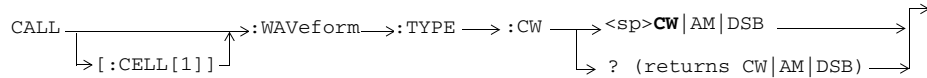

GPIB Syntax for E1966A, E1976A and E6706A/T

DISPlay

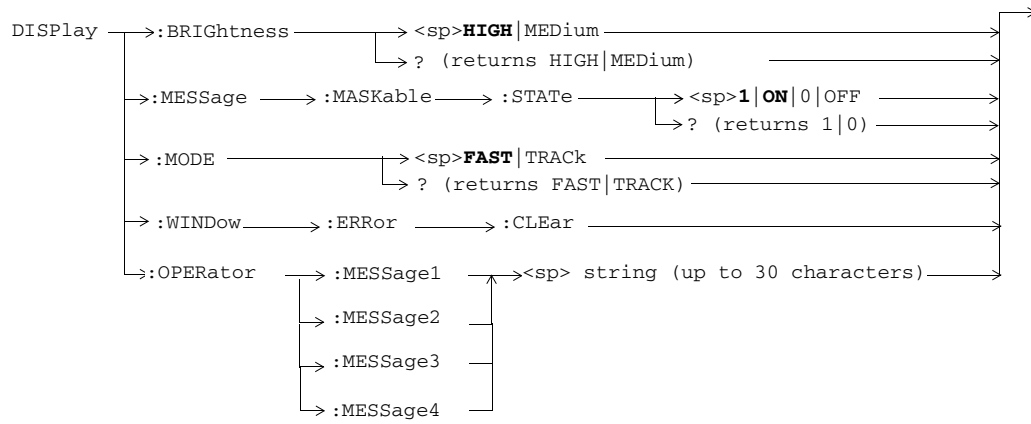

FETCH:AFANalyzer

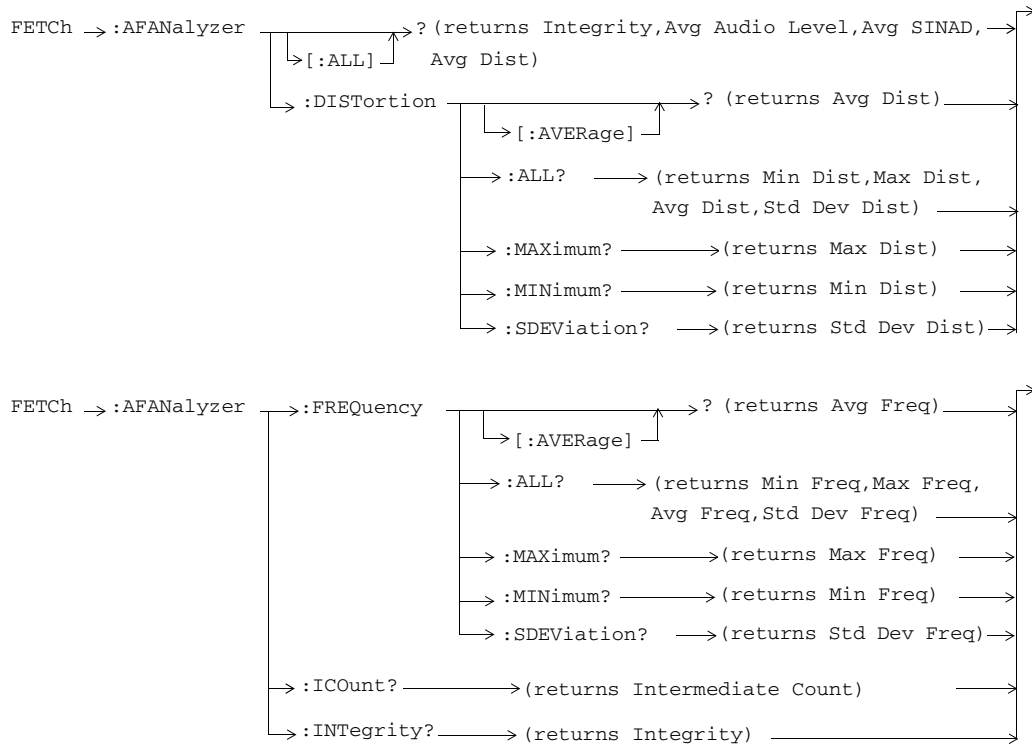

GPIB Syntax for E1966A, E1976A and E6706A/T

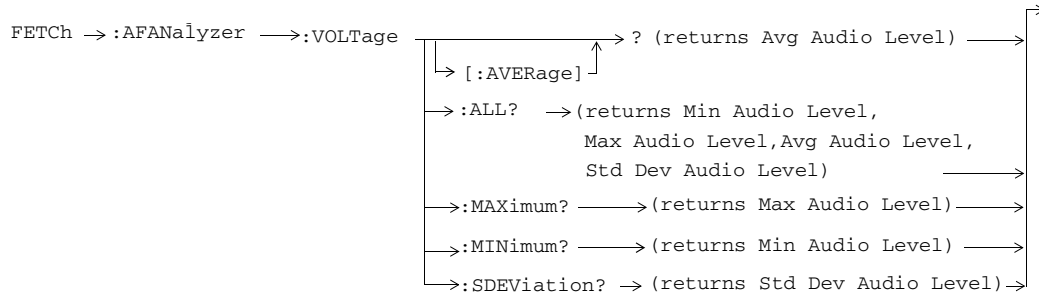
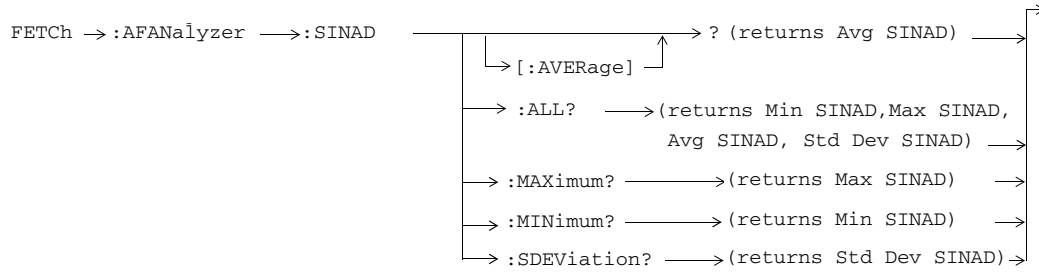

FETCH:CAPPower

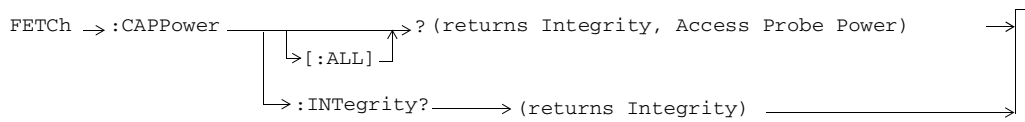

FETCH:CPError

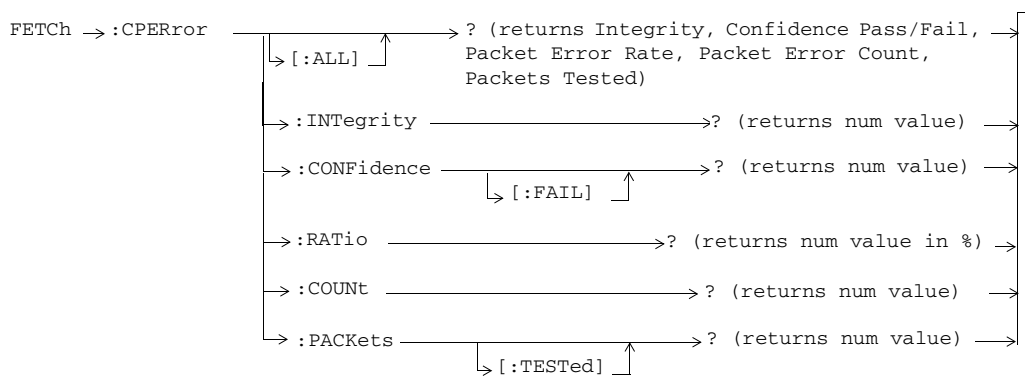

FETCH:CFDTune

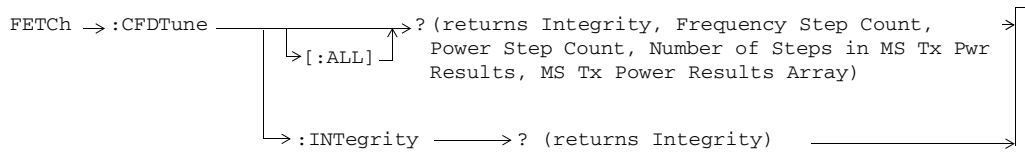

All commands shown in this diagram are only applicable to the lab application or feature-licensed test application.

GPIB Syntax for E1966A, E1976A and E6706A/T

FETCh:CPOWer

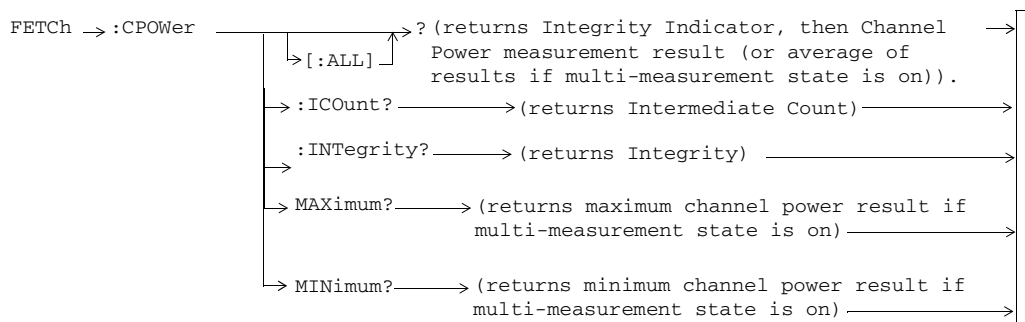

FETCh:CTDPower

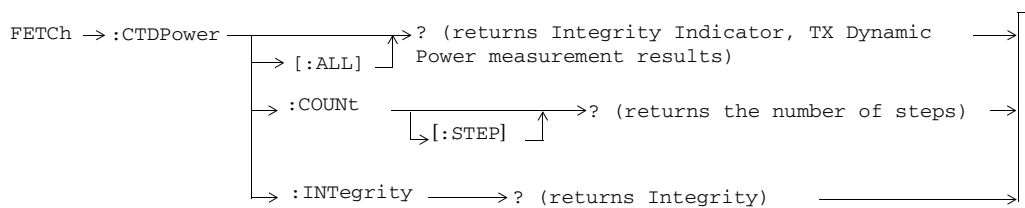

FETCh:CTXSpurious

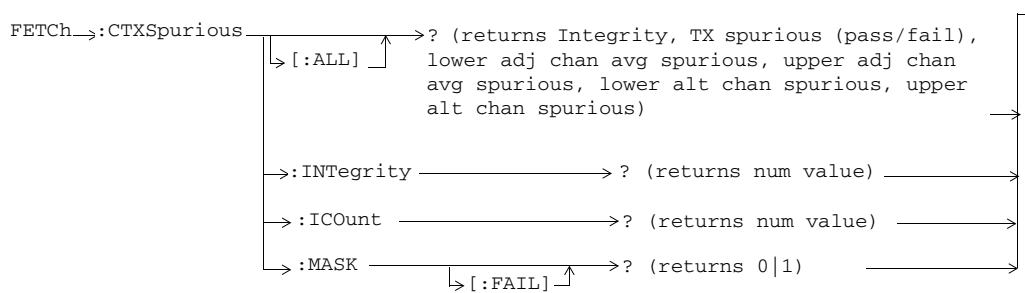

FETCH:DAPower

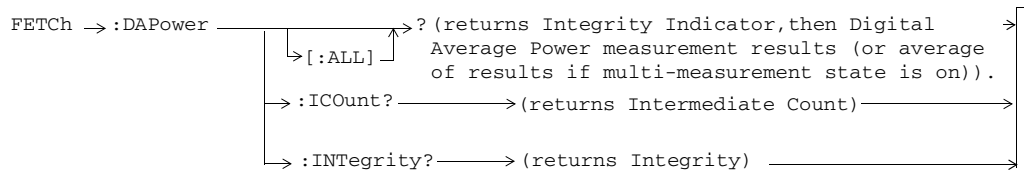

FETCH:DOWQuality

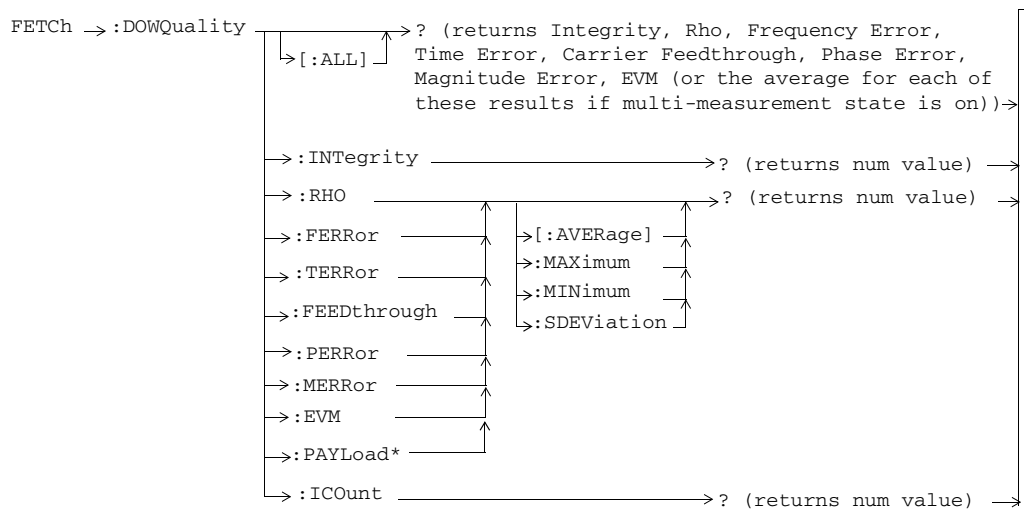

** Only applicable to the lab application and feature-licensed test application.*

GPIB Syntax for E1966A, E1976A and E6706A/T

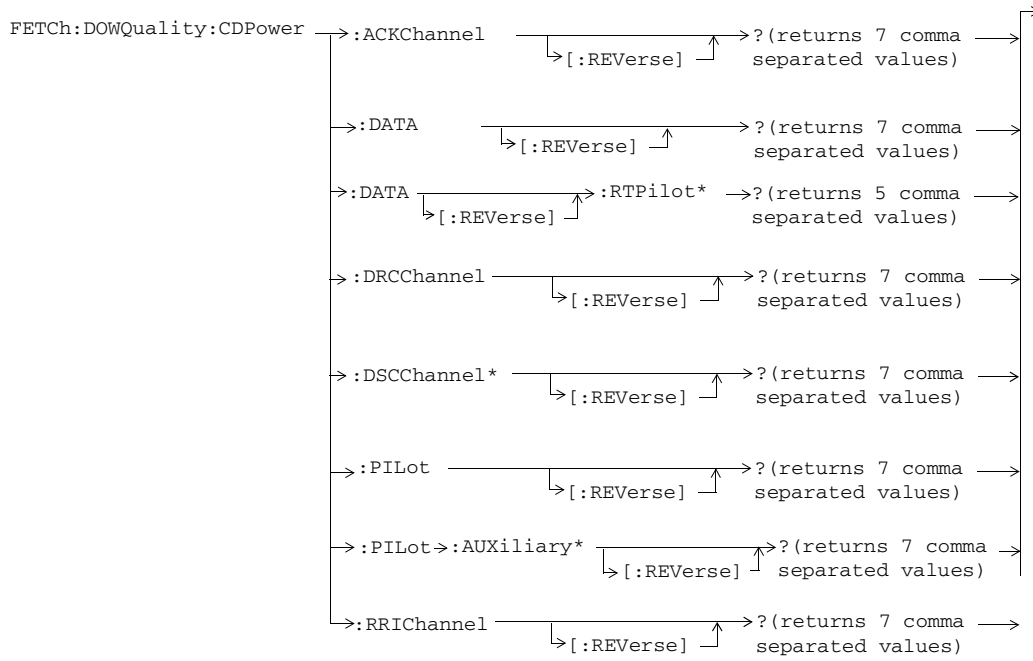

** Only applicable to the lab application and feature-licensed test application.*

GPIO Syntax for E1966A, E1976A and E6706A/T

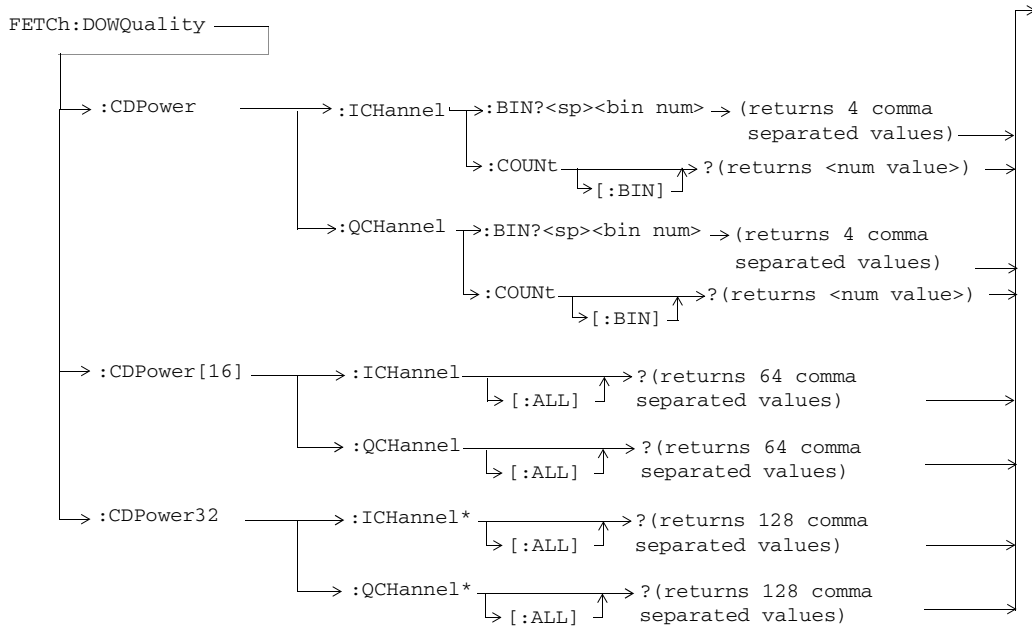

** Only applicable to the lab application and feature-licensed test application.*

GPIB Syntax for E1966A, E1976A and E6706A/T

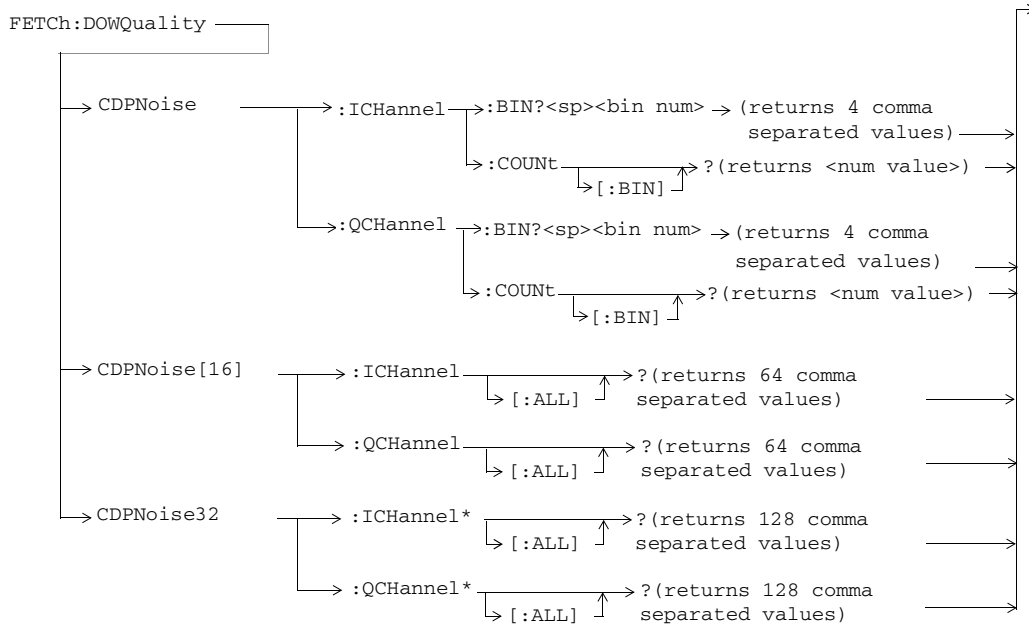

** Only applicable to the lab application and feature-licensed test application.*

FEtCh:GAPPower

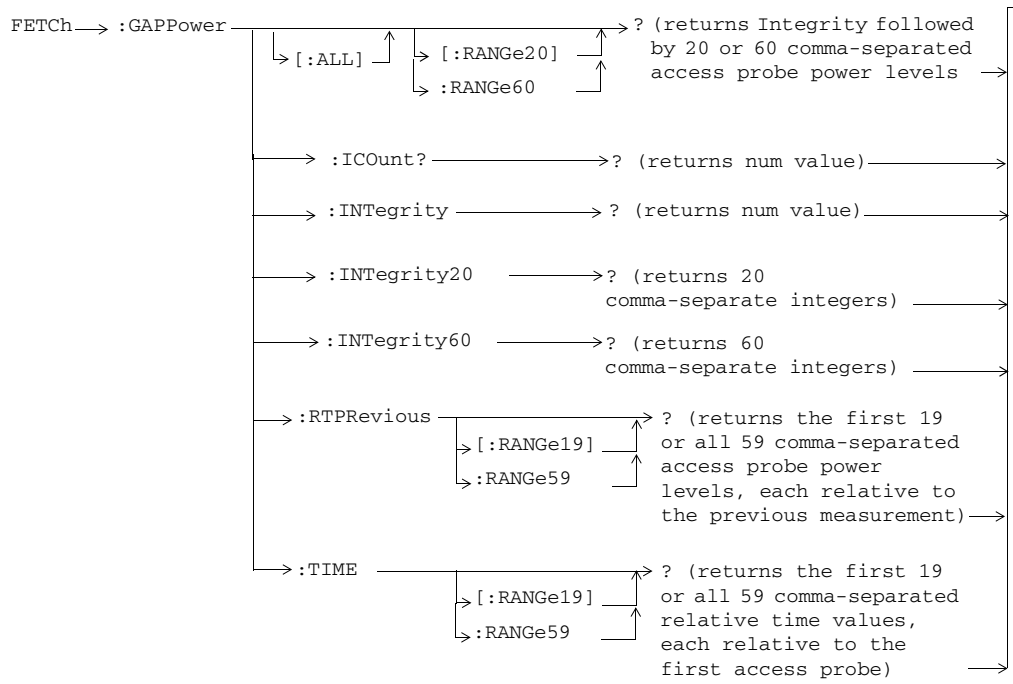

All commands shown in this diagram are only applicable to the lab application.

GPIB Syntax for E1966A, E1976A and E6706A/T

FETCh:SAUDio

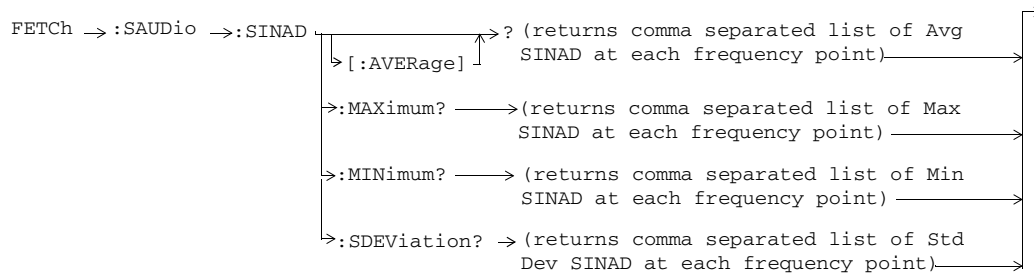
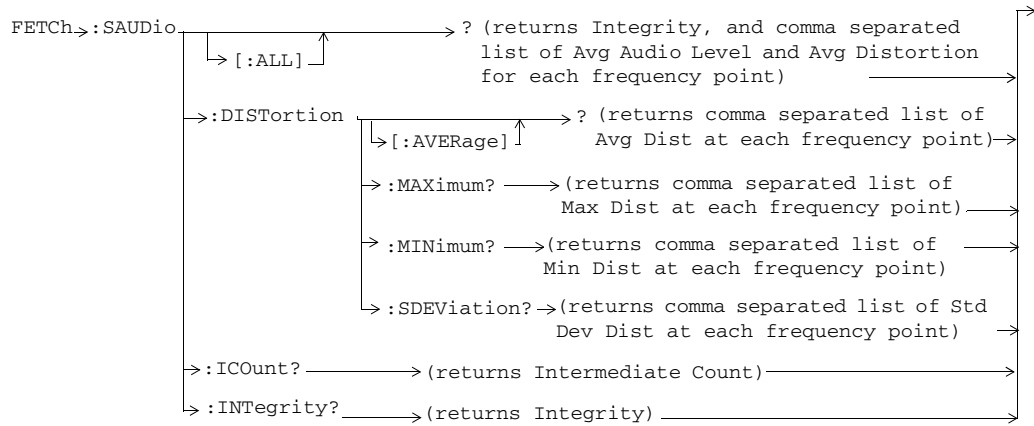

GPIB Syntax for E1966A, E1976A and E6706A/T

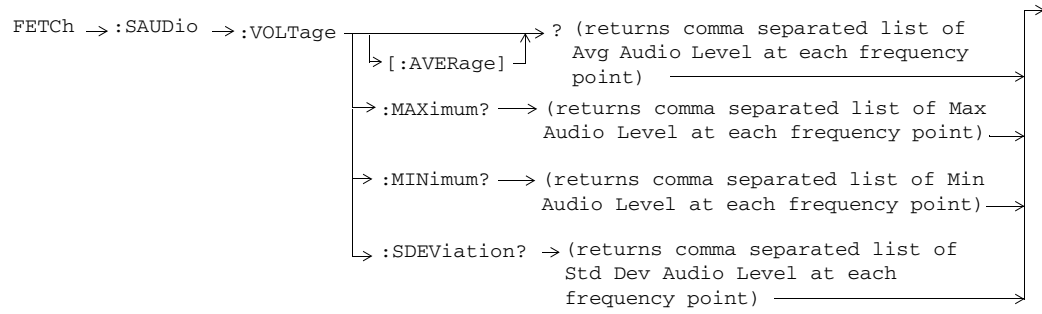

GPIB Syntax for E1966A, E1976A and E6706A/T

FETCh:SMONitor

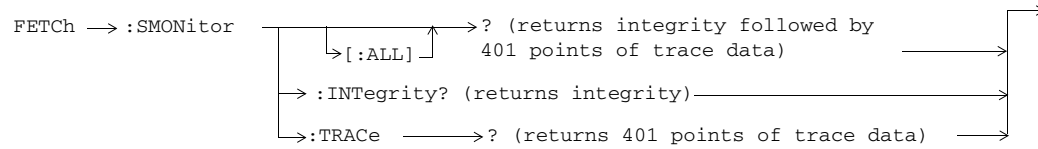

FETCh:TROPower

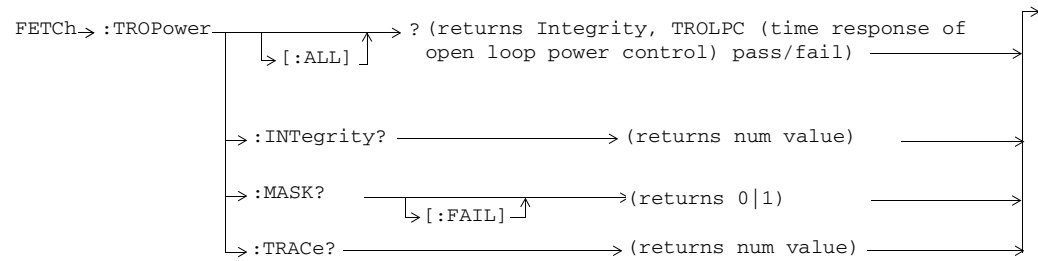

INITiate

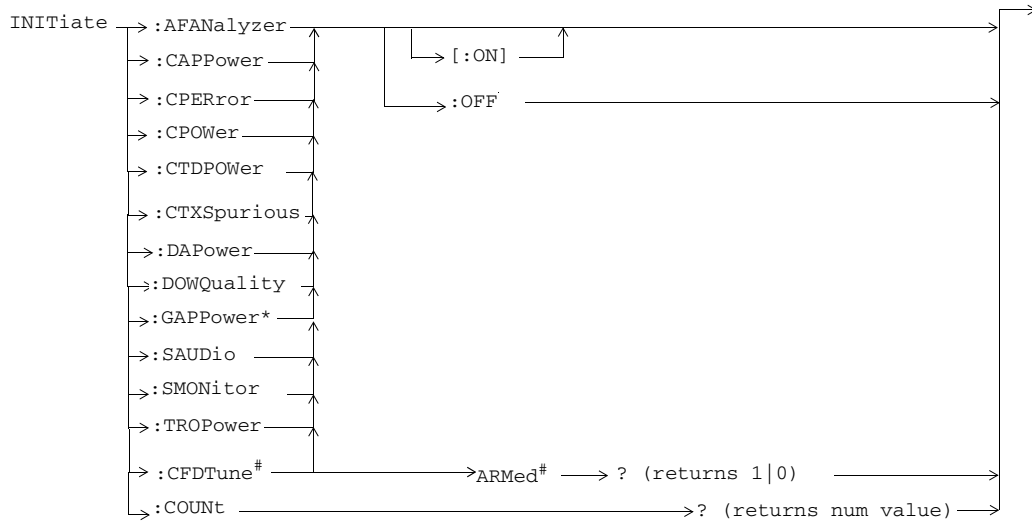

Only applicable to the lab application or feature-licensed test application.

* Only applicable to the lab application.

GPIB Syntax for E1966A, E1976A and E6706A/T

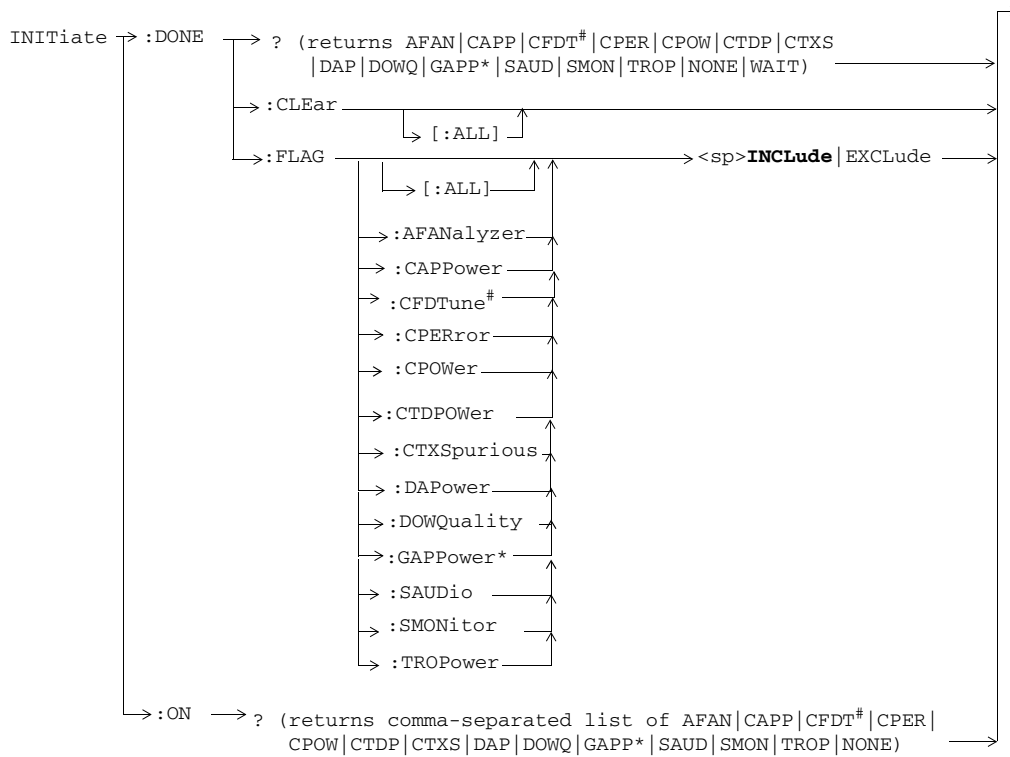

Only applicable to the lab application or feature-licensed test application.

* Only applicable to the lab application.

READ

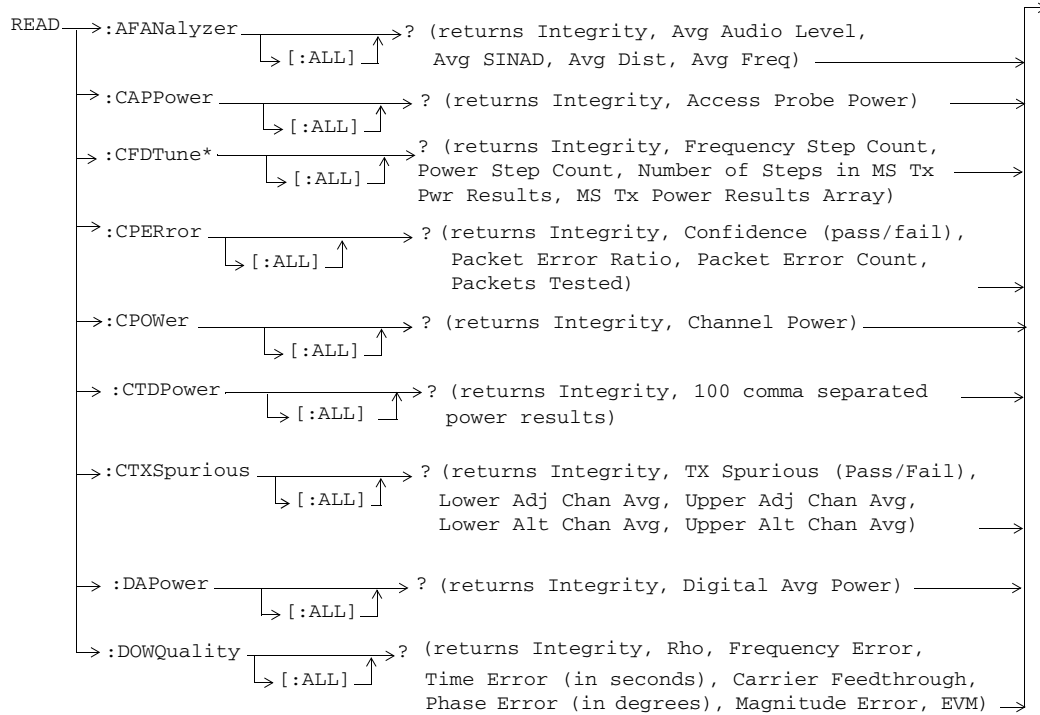

* Only applicable to the lab application or feature-licensed test application.

GPIB Syntax for E1966A, E1976A and E6706A/T

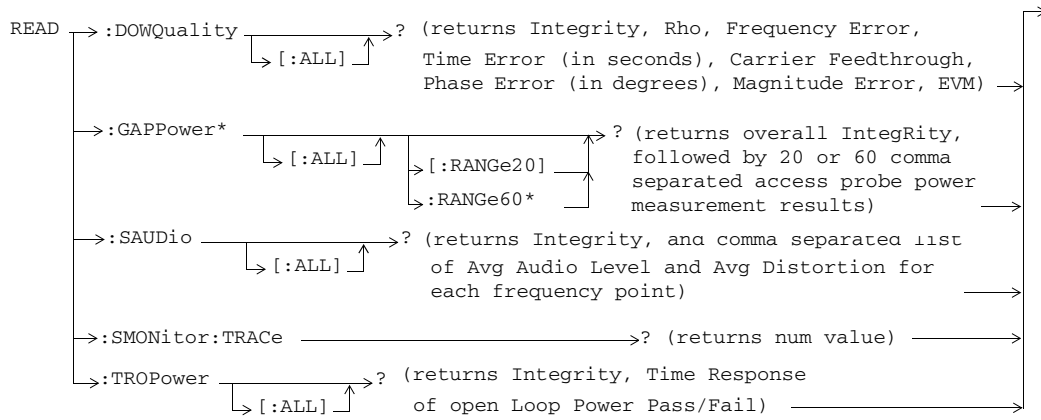

* Only applicable to the lab application.

RFAnalyzer

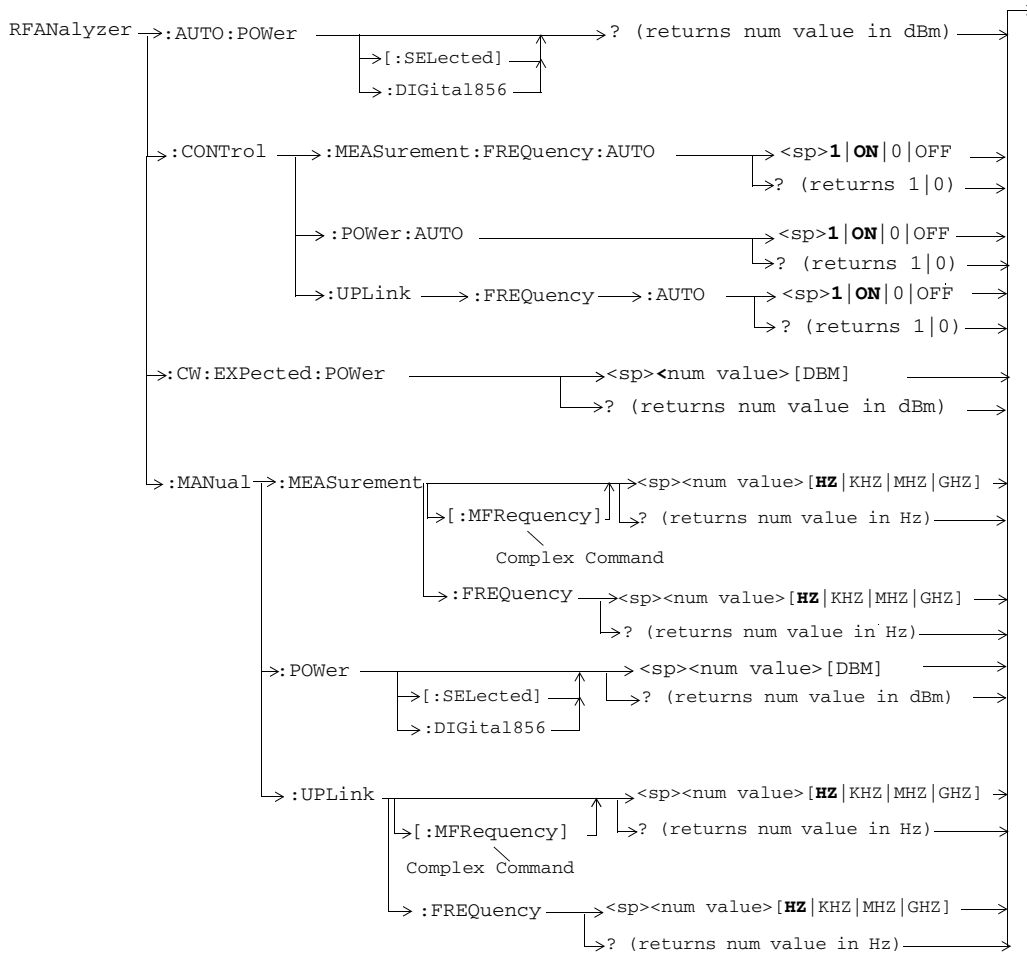

GPIB Syntax for E1966A, E1976A and E6706A/T

RFGenerator:OUTPut

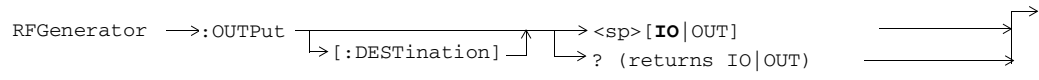

SETup:CONTInuous

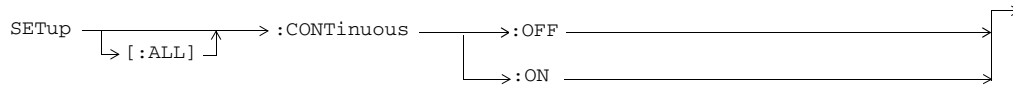

SETup:AFANalyzer

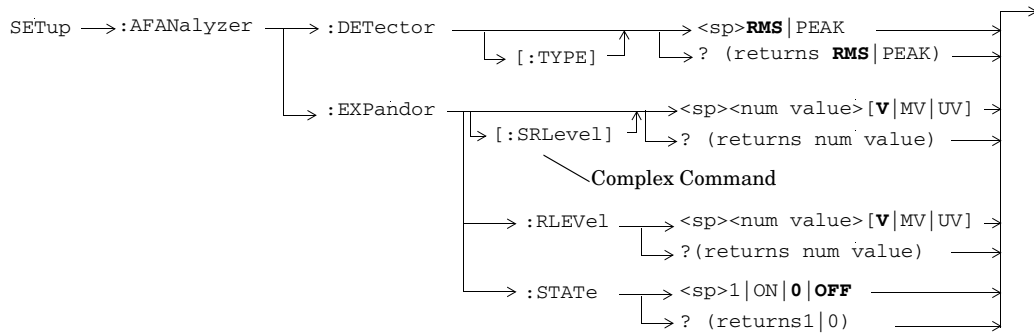
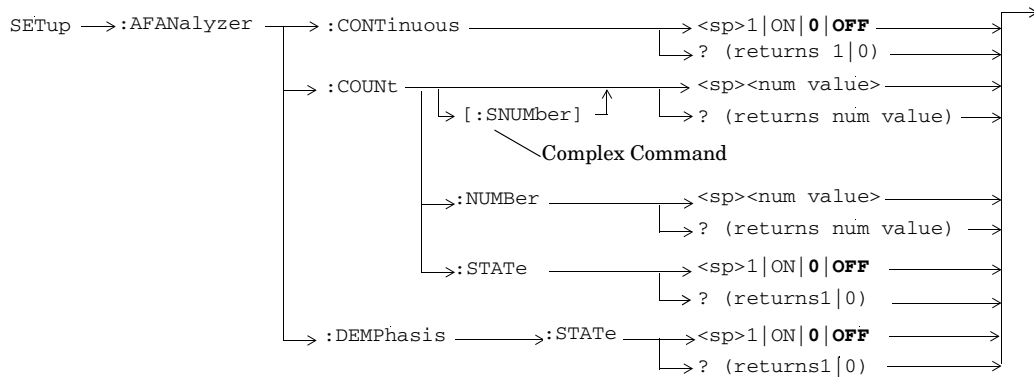

GPIB Syntax for E1966A, E1976A, and E6706A/T

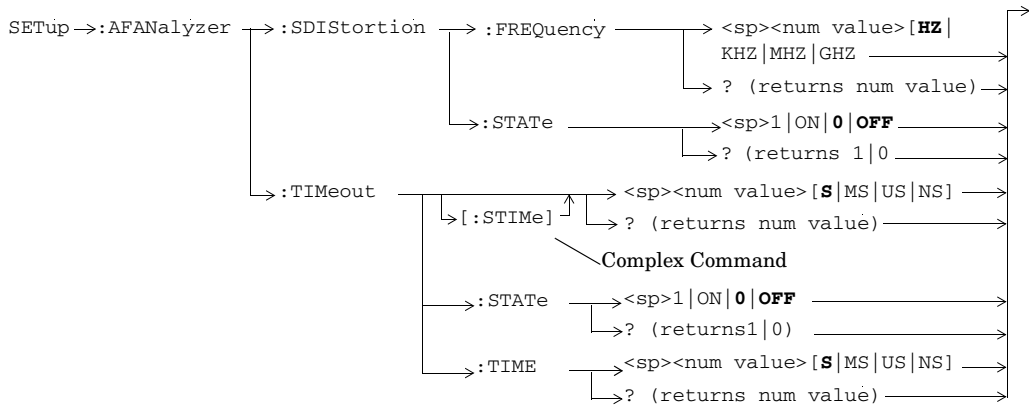
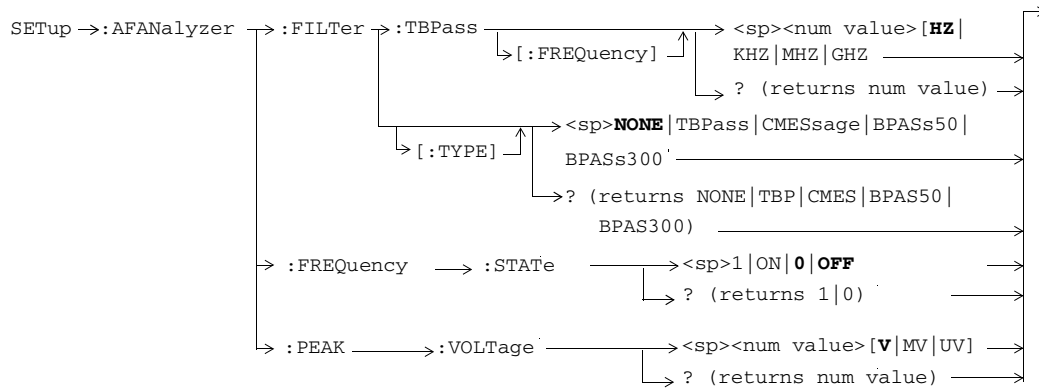

SETup:CAPPower

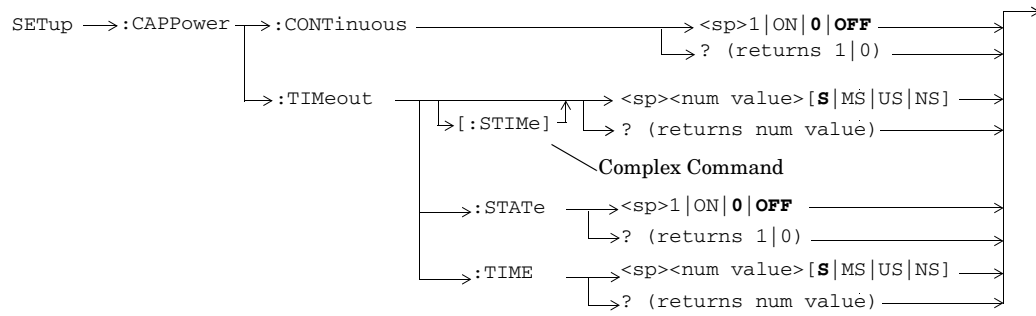

GPIB Syntax for E1966A, E1976A, and E6706A/T

SETup:CFDTune

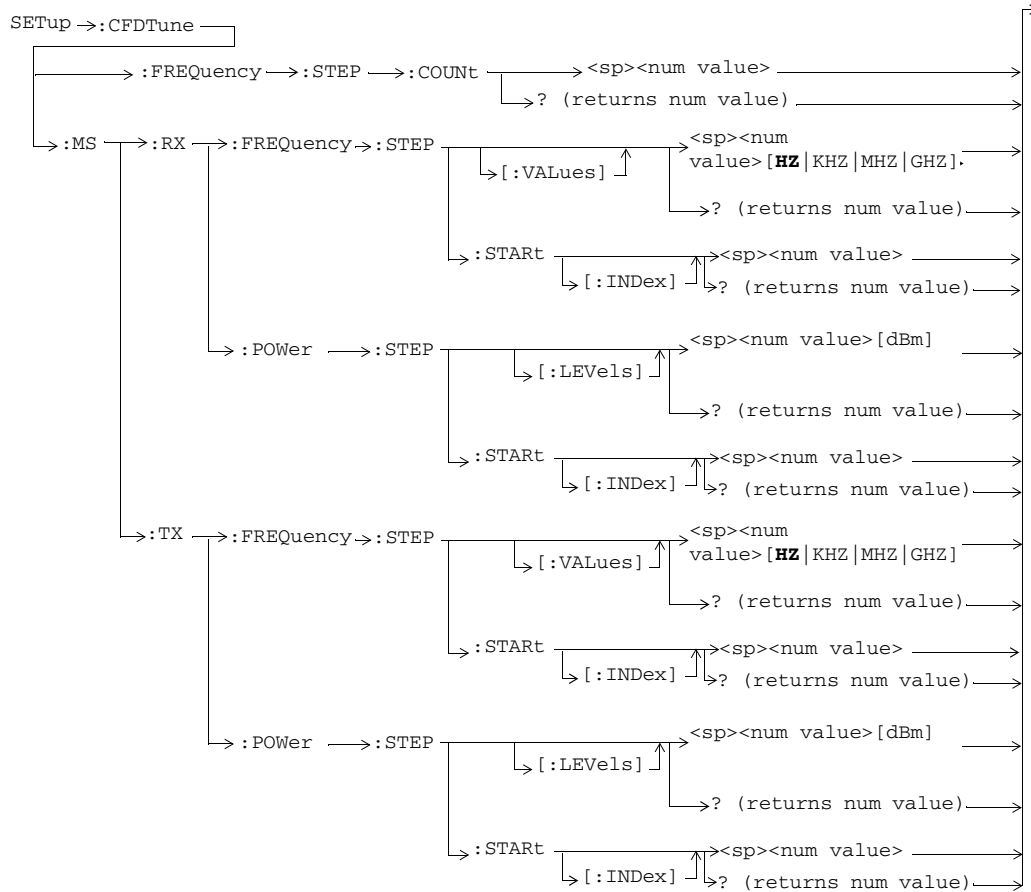

All commands shown in this diagram are only applicable to the lab application or feature-licensed test application.

GPIB Syntax for E1966A, E1976A, and E6706A/T

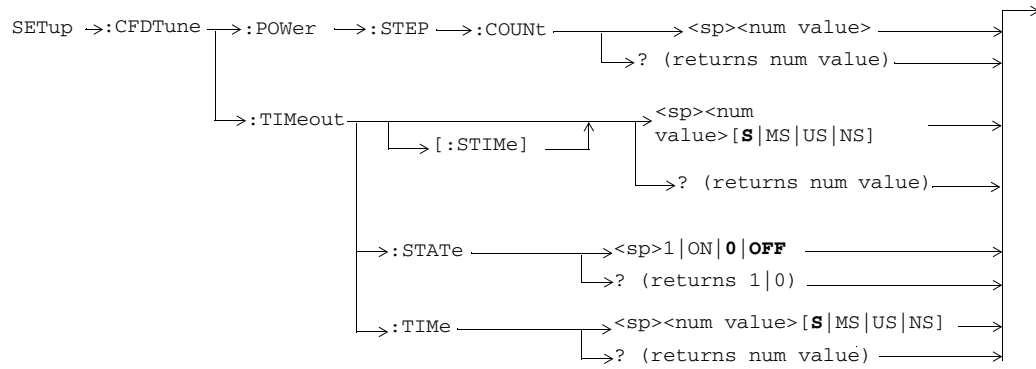

All commands shown in this diagram are only applicable to the lab application or feature-licensed test application.

SETup:CPERror

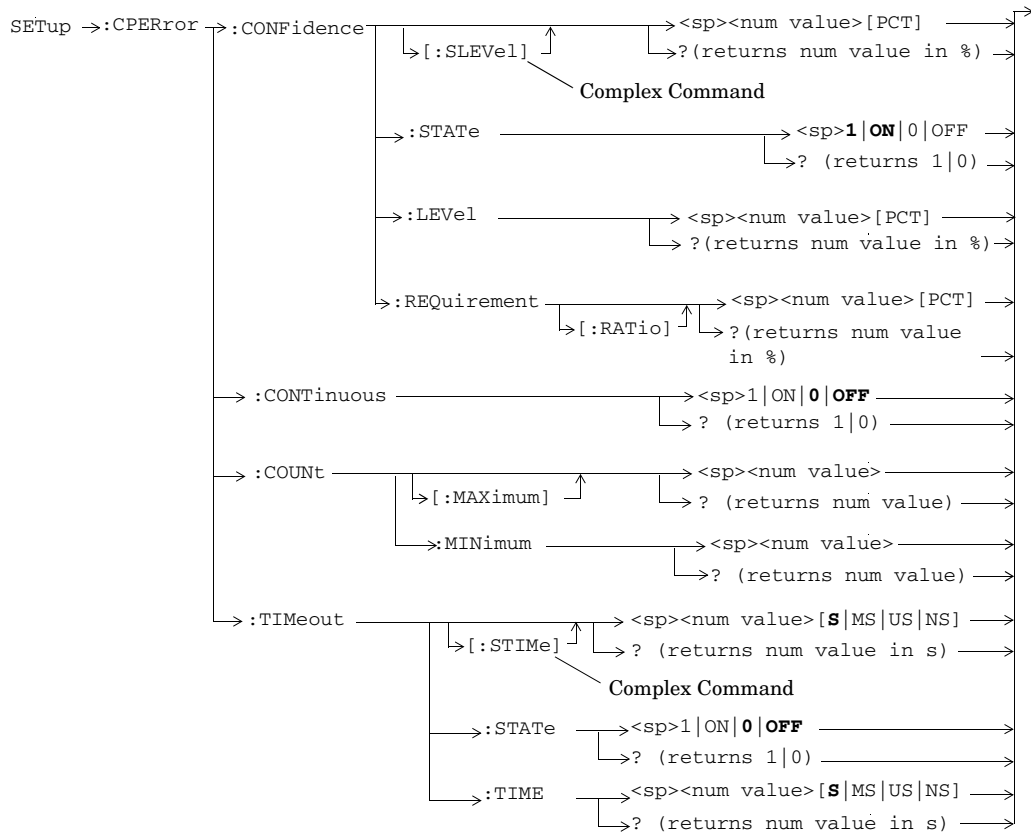

SETup:CPOWer

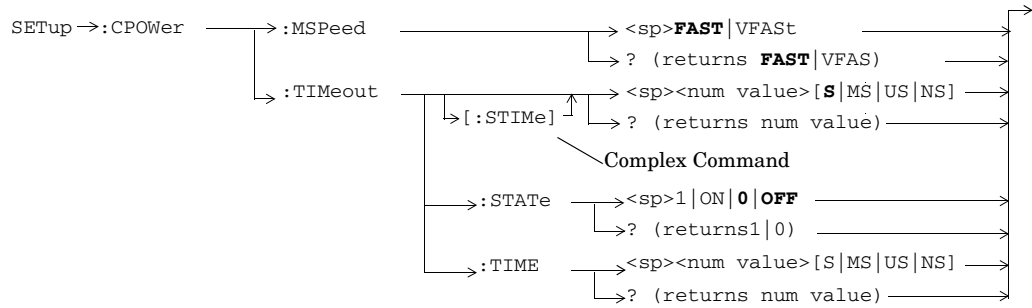
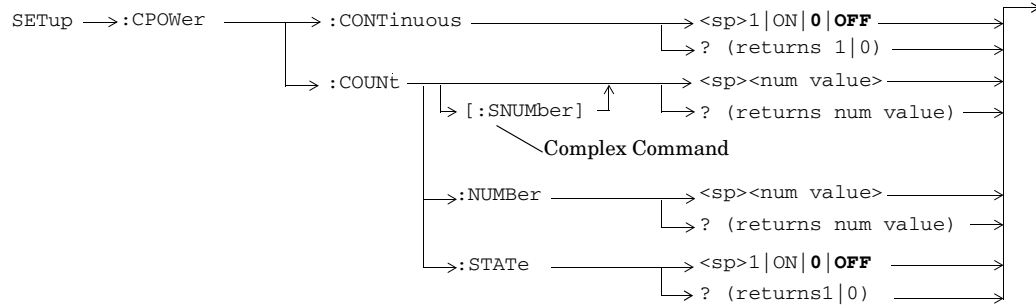

SETup:CTDPower

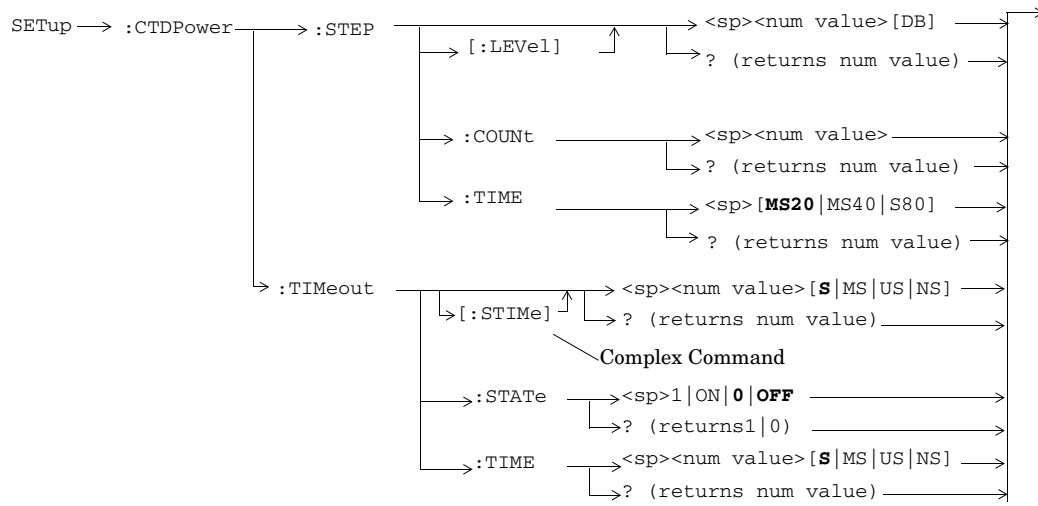

SETup:CTXSpurious

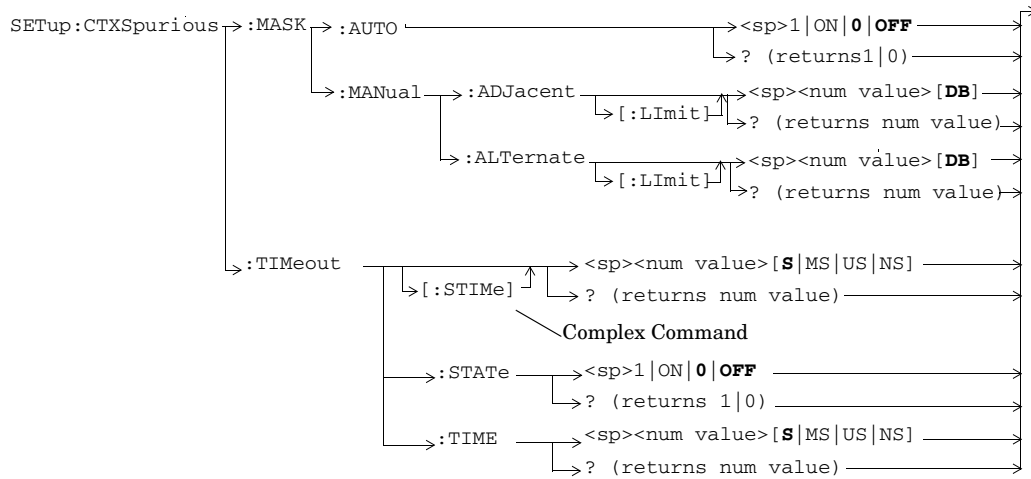
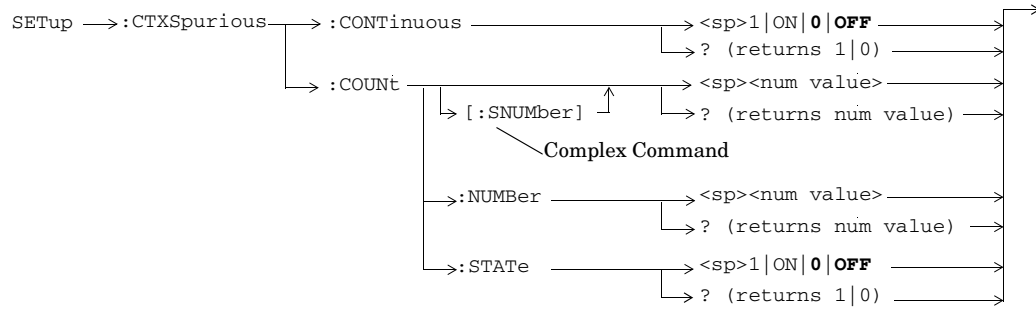

GPIB Syntax for E1966A, E1976A, and E6706A/T

SETup:DAPower

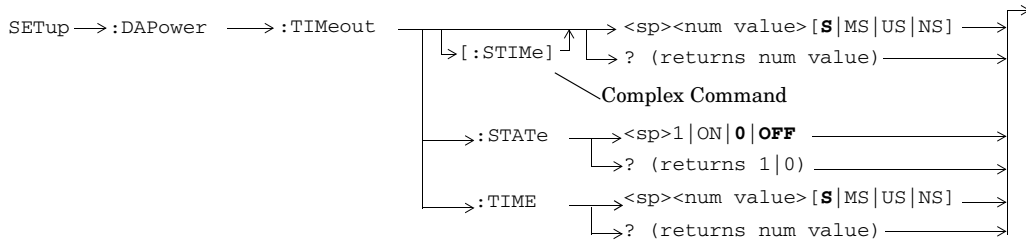
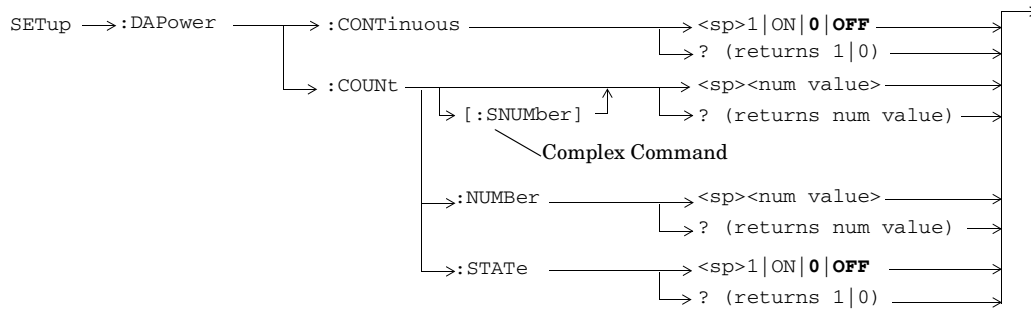

SETup:DOWQuality

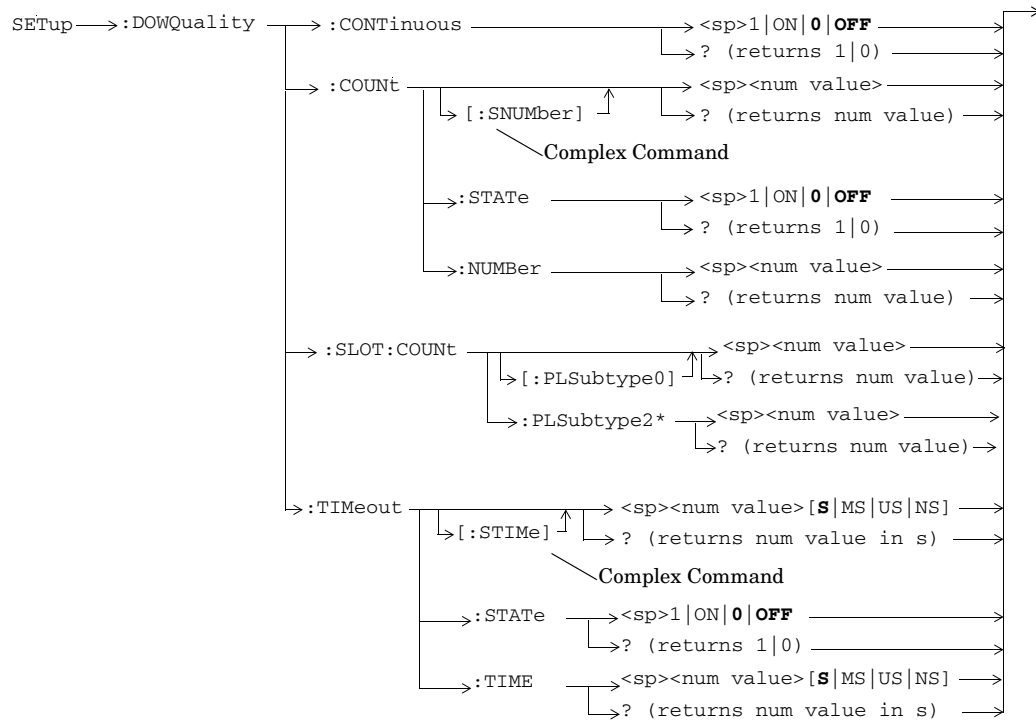

* Only applicable to the lab application and feature-licensed test application.

GPIB Syntax for E1966A, E1976A, and E6706A/T

SETup:GAPPower

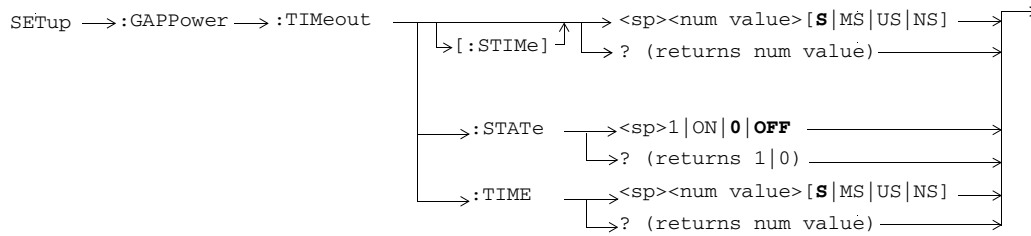

All commands shown in this diagram are only applicable to the lab application.

SETup:SAudio

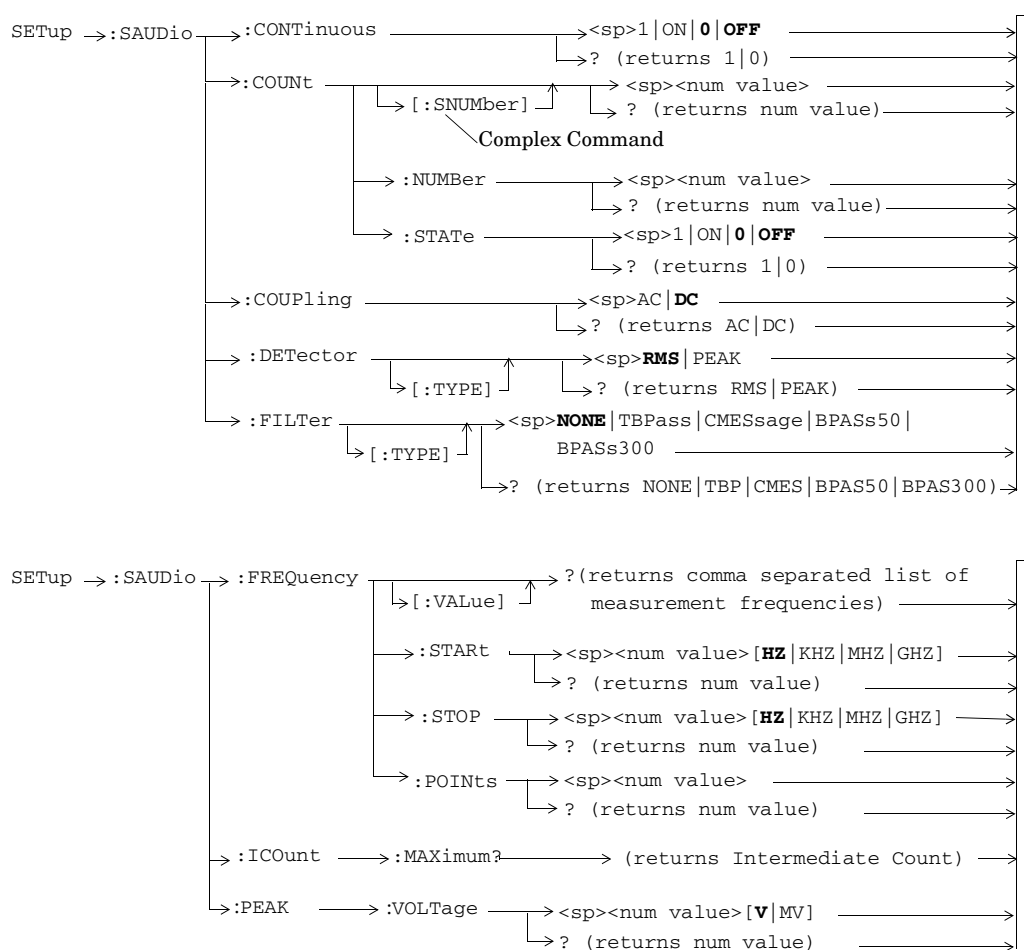

GPIB Syntax for E1966A, E1976A, and E6706A/T

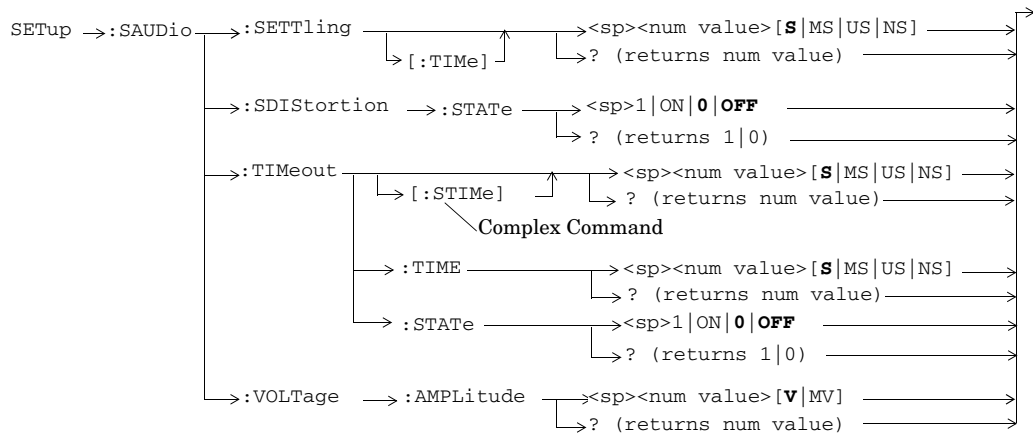

SETup:SMONitor

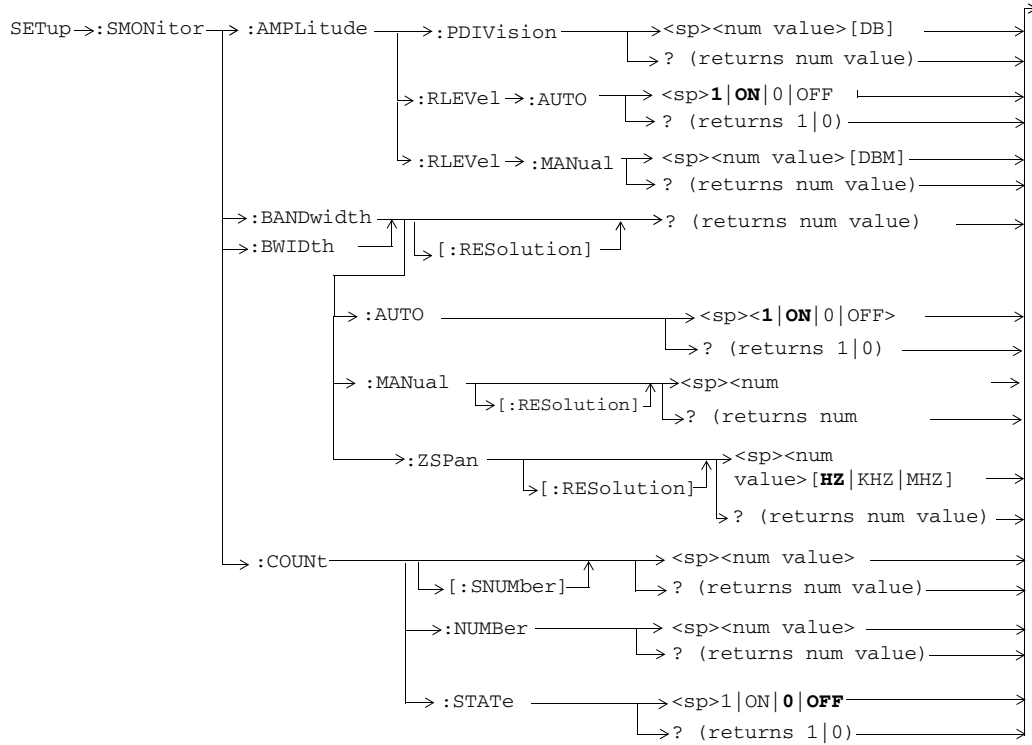

GPIB Syntax for E1966A, E1976A, and E6706A/T

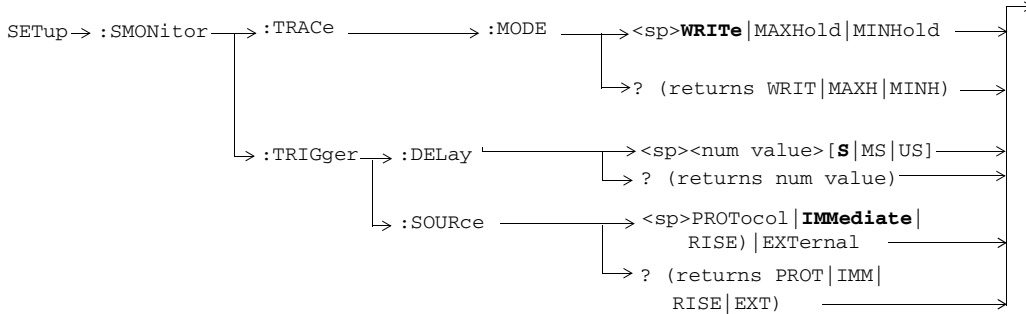
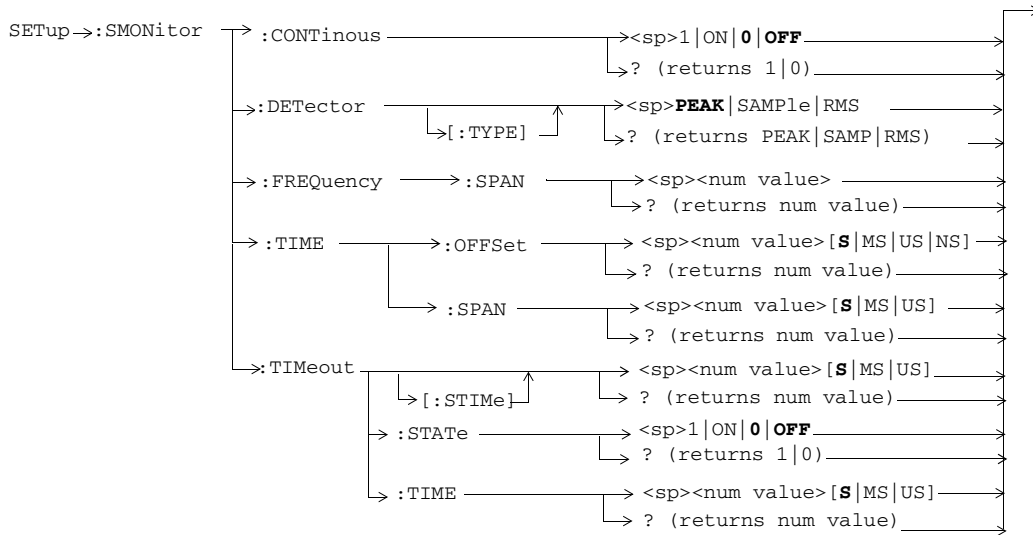

SETup:TROPower

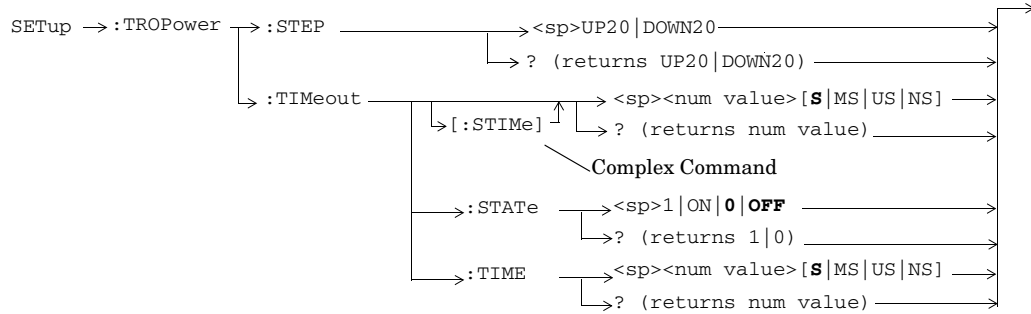

STATus:OPERation

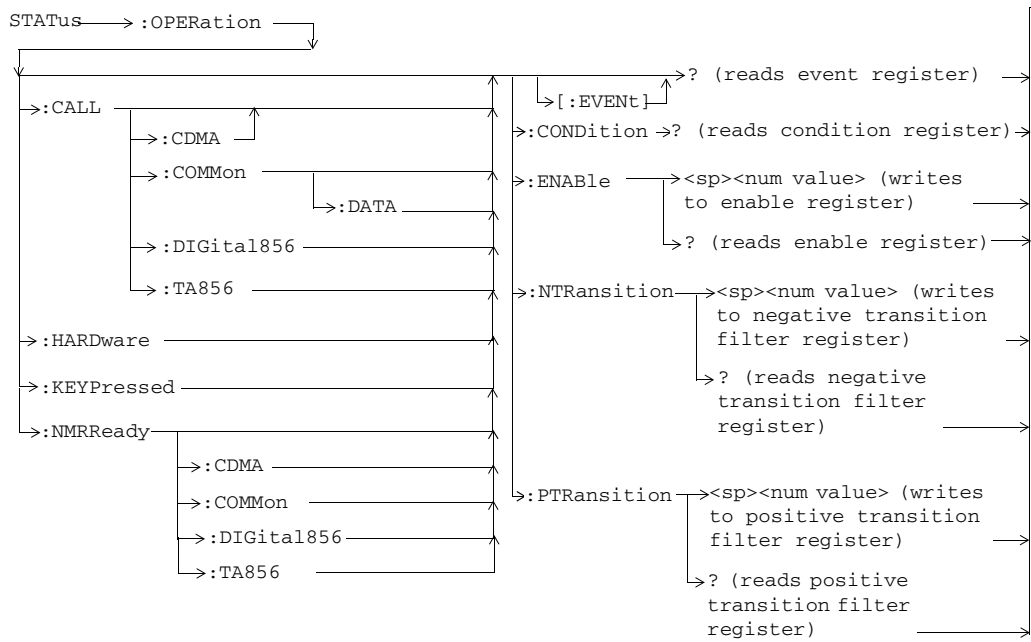

STATus:PRESet

STATus → :PRESet →

STATus:QUEStionable

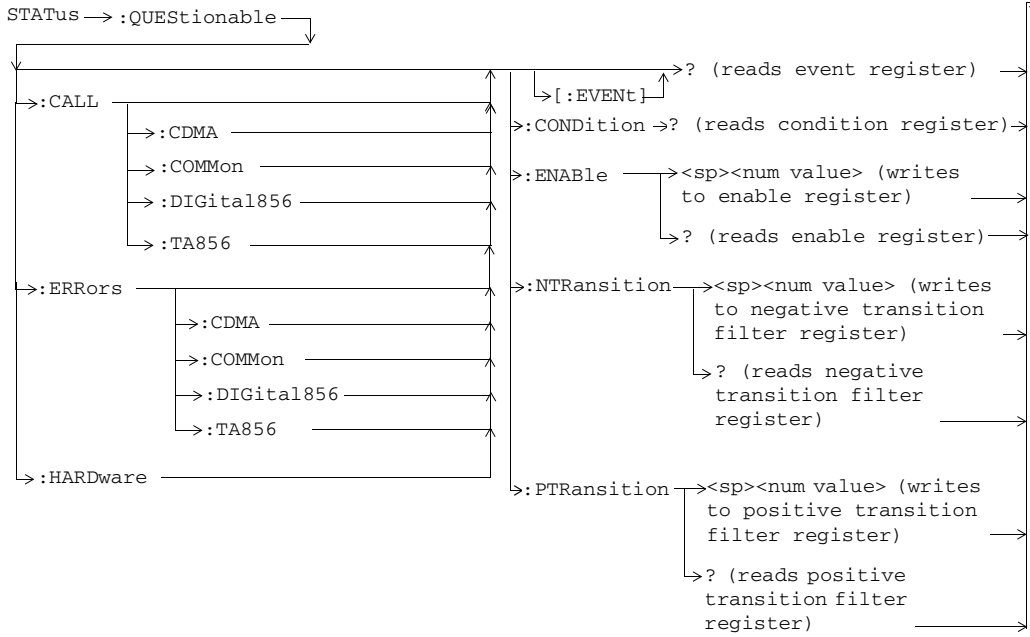

Status Byte Register

***STB?**

*STB? _____ →

Standard Event Status Register

***ESR?**

*ESR? _____ → Reads and clears the Std Event Status Register. _____ →

***ESE?**

*ESE? _____ → Reads the Std Event Status Register Enable Register _____ →

***ESE**

*ESE _____ → Writes to the Std Event Status Register Enable Register _____ →

SYSTem:APPLication

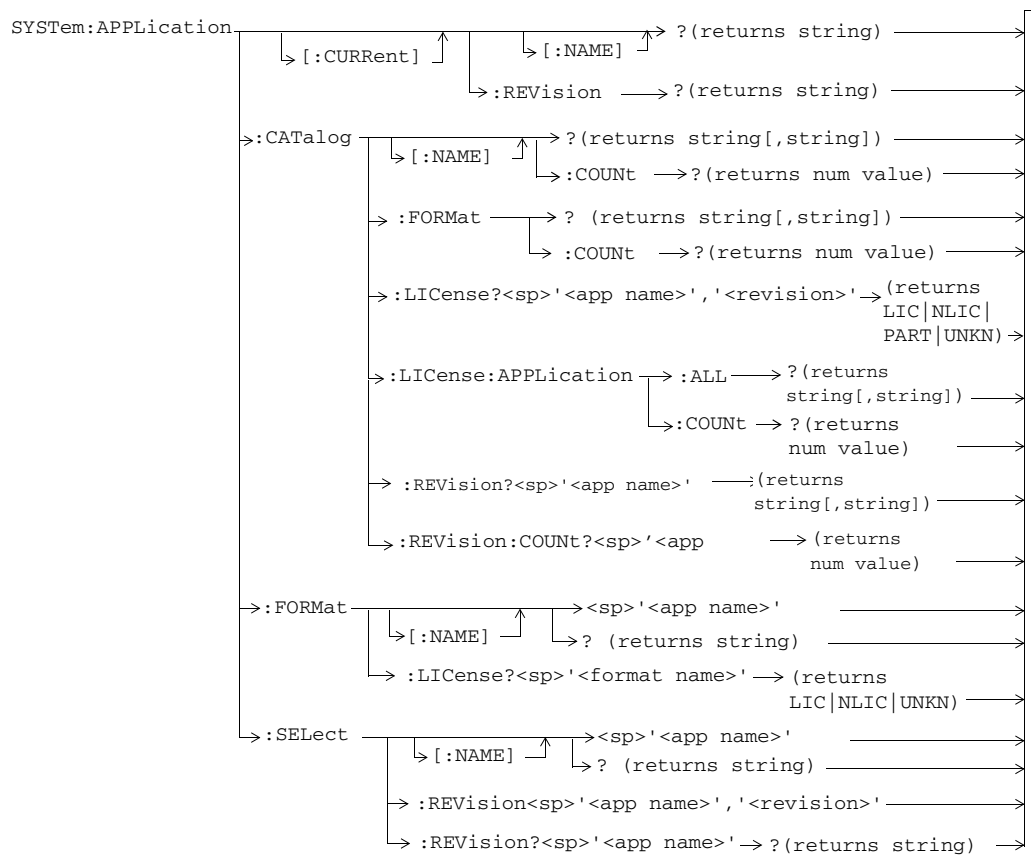

SYSTEM:Audio

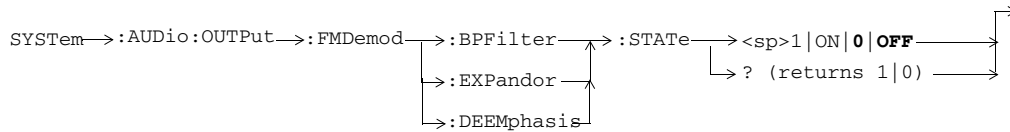
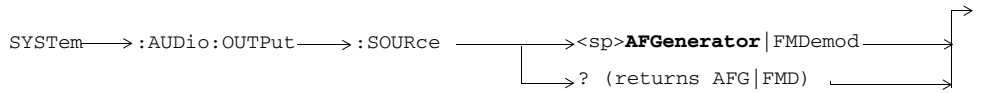

SYSTEM:BEEPER

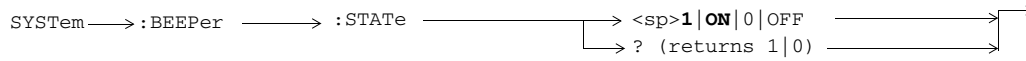

SYSTEM:COMMUNICATE

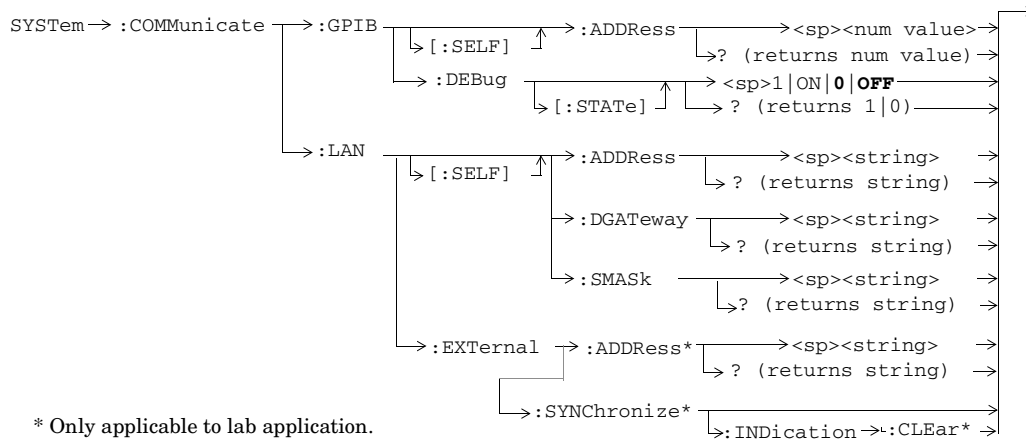

* Only applicable to lab application.

GPIO Syntax for E1966A, E1976A, and E6706A/T

SYSTEM:CONFigure

SYSTEM → :CONFigure → :INformation → :HARDware → :VERBose? →

SYSTEM:CORRection

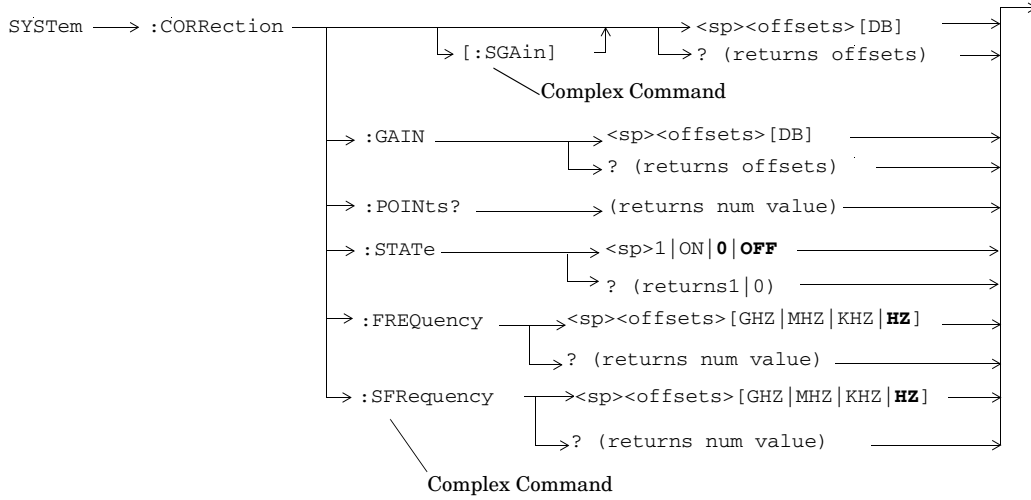

SYSTEM:CURRent:TA

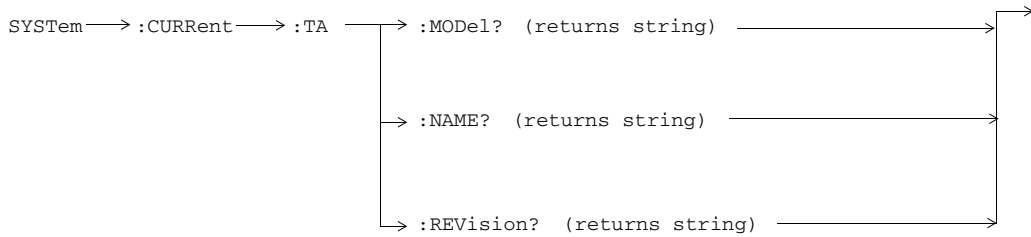

SYSTEM:DATE

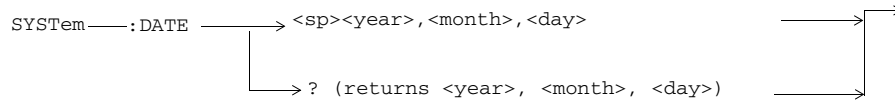

SYSTEM:ERROR?

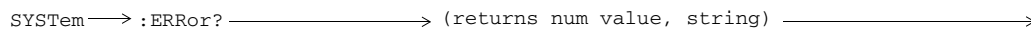

SYSTEM:FATAL

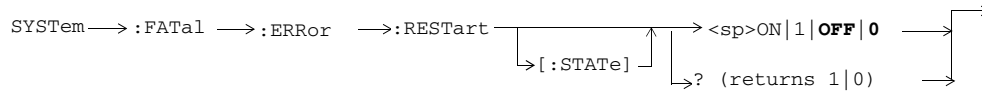

SYSTEM:INSTRUMENT

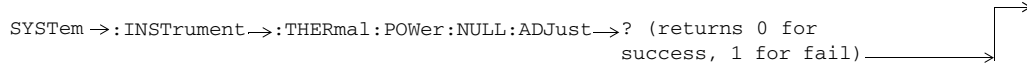

SYSTEM:MEASUREMENT:RESET

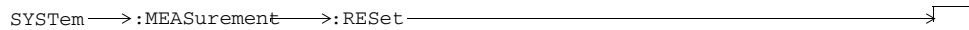

SYSTEM:PRESET

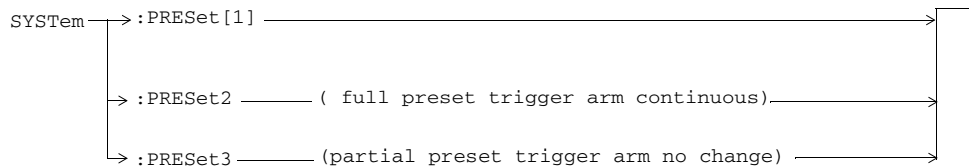

GPIB Syntax for E1966A, E1976A, and E6706A/T

SYSTEM:REGister

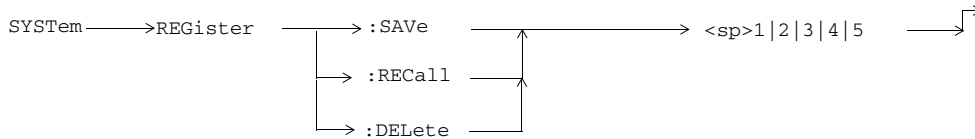

SYSTEM:ROSCillator

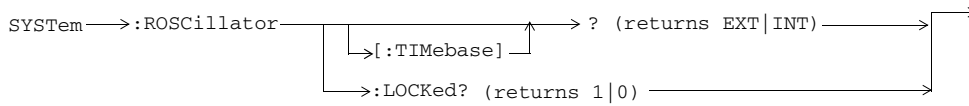

SYSTEM:SYNChronized

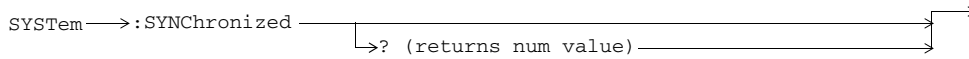

SYSTEM:STATus

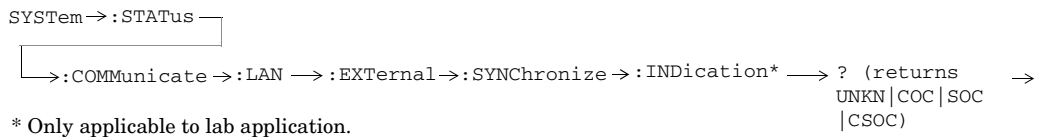

* Only applicable to lab application.

SYSTEM:TIME

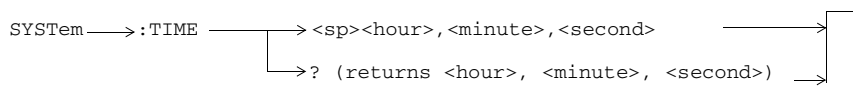

SYSTem:TZONE

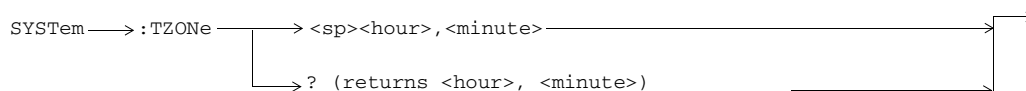

SYSTem:UTC

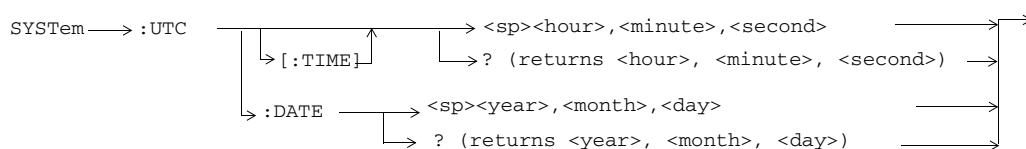

IEEE 488.2 Common Commands

Description

***CLS** The *CLS, clear status command, is defined in “IEEE Std 488.2-1992”, 10.3. This command will also clear and close the error message screen on the test set’s display.

***ESE** The *ESE, standard event status enable command, is defined in “IEEE Std 488.2-1992”, 10.10.

***ESE?** The *ESE?, standard event status enable query, is defined in “IEEE Std 488.2-1992”, 10.11.

***ESR?** The *ESR?, standard event status register query, is defined in “IEEE Std 488.2-1992”, 10.12.

***IDN?** The *IDN?, identification query, is defined in “IEEE Std 488.2-1992”, 10.14. *IDN? is used to retrieve information about the test set in ASCII format.

*IDN?, returns ASCII codes 32 through 126 excluding comma and semicolon in four comma separated fields. Field 1 returns the manufacturer, field 2 returns the instrument model number, field 3 returns the serial number, field 4 returns 0.

***OPC** The *OPC, operation complete command, is defined in “IEEE 488.2-1992”, 10.18. *OPC causes the test set to continuously sense the No Operation Pending flag. When the No Operation Pending flag becomes TRUE, the OPC event bit in the standard event status register (ESR) is set to indicate that the state of all pending operations is completed. The *OPC common command is not recommended for use as an overlapped command.

***OPC?** The *OPC?, operation complete query, is defined in “IEEE Std 488.2-1992”, 10.19. The *OPC? query allows synchronization between the controller and the test set using either the message available (MAV) bit in the status byte, or a read of the output OPC?. The *OPC? query does not effect the OPC event bit in the Standard Event Status Register (ESR). The *OPC? common command is not recommended for use as an overlapped command.

GPIB Syntax for E1966A, E1976A, and E6706A/T

***OPT?** The *OPT?, option identification query, is defined in “IEEE Std 488.2-1992”, 10.20. Each option will have a unique name, that name will be returned with the query.

***RST** The *RST, full preset command, is defined in “IEEE Std 488.2-1992”, 10.32. *RST is the recommended command when performing a full preset on the test set. A *RST restores the majority of settings to their default values.

- *RST sets trigger arm to single
- PRESet2 sets trigger arm to continuous

***SRE** The *SRE, service request enable command, is defined in “IEEE Std 488.2-1992”, 10.34. The parameter range for this command is 0 through 255.

***SRE?** The *SRE?, service request enable query, is defined in “IEEE Std 488.2-1992”, 10.35. Values returned by this query range from 0 through 255.

***STB?** The *STB?, read status byte query, is defined in “IEEE Std 488.2-1992”, 10.36. Values returned by this query range from 0 through 255.

***WAI** The *WAI, wait-to-continue command, is defined in “IEEE Std 488.2-1992”, 10.39. The *WAI command prevents the test set from executing any further commands or queries until all pending operation flags are false. The *WAI common command is not recommended for use as an overlapped command.

Index

To find a syntax equivalent for a field on the Test Set's display.

1. Find the field name on the Test Set's display.
2. Look up the name in the alphabetical listing.
3. Turn to the page indicated.

Numerics

-0.885 MHz Offset, 44
0.885 MHz Offset, 44
-1.98 MHz Offset, 44
1.98 MHz Offset, 44
100 Hz BW BPF Center Frequency
audio analyzer, 60

A

Abort Measurement, 9
Access Probe Power, 43
Ack Channel Gain, 29
ACK R-Data After, 28
Active Cell Operating Mode, 32
Alternate Ping Address, 25
Amplitude, 10
Application Configuration
 Expected Enhanced Access Rate, 36
Application Selection, 78
Application Setup, 78
Application Switch, 78
Application, Revision, License, 78
AT Directed Packets, 14
AT Max Power, 29
Audio Analyzer Setup
 SINAD/Distortion Fundamental Frequency, 60
Audio Frequency, 41
Audio Generator, 10
Audio Generator Coupling, 71
Audio Generator Level, 72
Audio Level, 42
Audio Out Port, 79
Auxiliary Pilot Channel Gain, 29
Auxiliary Pilot Channel Min Payload, 29
AWGN Power, 16, 36
AWGN Power State, 36

B

Band, 16
Band Pass Filter Frequency FM, 60
Beeper State, 79

C

Cal. Burst Mod Offset 1, 11
Cal. first IQ Modulator, 11
Cal. second IQ Modulator, 11
Calibrate Channel Power, 11
Calibrate Digital Avg Pwr, 11
Call Drop Timer, 18
Call Limit Mode, 18
Carrier Feedthrough, 45
CDMA System Time Information, 37
Cell Band, 16
Cell Band, Handoff, 34
Cell Channel, 17
Cell Power, 33, 36
Cell Power State, 36
Channel, 17
Channel Power, 44
Channel, Handoff, 34
Close Session, 34
Code Domain Power, 46
Code Domain Power + Noise, 48
Color Code, 17
Continuous, 59
Control Channel Data Rate, 17
Corrupted Bursts, 19, 23
Country Code, 28
Coupling, 10
Current Physical Layer Subtype, 37
Current System Type, 36
CW Operating Mode, 32

D

Data Connection State, 27
Data Connection State Change Detector, 27
Data Connection State Change Detector Timeout, 27
Data Connection Status, 36
Data Offset 153k6, 29
Data Offset 19k2, 29
Data Offset 38k4, 29
Data Offset 76k8, 29
Data Offset 9k6, 29
Data Offset Nom, 29
Data Throughout Monitor, 23
Date (yyyy.mm.dd), 81
Decode Errors, 19, 23
De-Emphasis State

audio analyzer, 59
Default Gateway, 79
DELETE hardkey, 82
Detector Type, 71
 Peak (audio analyzer), 60
 RMS (audio analyzer), 60
Device Settling Time, 72
Device to Ping, 25
Digital Average Power, 45
Display Brightness, 40
Display Mode, 40
Distortion
 audio, 41
 Swept Audio, 50
DRC Channel Gain, 29
DRC Value Fixed Mode Attribute, 14
DSC Channel Gain, 29
DSC Length, 29
DUT IP Address, 29

E

Eb/Nt, 37
End Data Connection, 27
Enhanced Access Rate, 14
Enhanced Test Application Protocol, 14
EVM, 45
Execute Handoff, 27
Expander Reference Level
 audio analyzer, 60
Expected CW Power, 57
Expected Peak Voltage, 71
Expected Power
 DIGital856, 57
Expected Reverse Data Channel Info
 Packet Size, 36
 T2P Transition, 37
 Transmission Mode, 36
 TxT2P Post-Transition, 37
 TxT2P Pre-Transition, 37
External Trigger Type, 39
ExtRef, 82

F

Filter Type, 71
100 Hz BW BPF (audio analyzer), 60
300 Hz to 15 kHz (audio analyzer), 60
50 Hz to 15 kHz (audio analyzer), 60
C-Message (audio analyzer), 60
None (audio analyzer), 60
FM Demodulation Setup
 Bandpass Filter State, 79

Index

- Deemphasis State, 79
 - Expander State, 79
 - Force Dormant, 27
 - Frequency, 10
 - Frequency (MHz)
 - amplitude offset, 80
 - Frequency Band, 16
 - Frequency Error, 45
 - FTAP Rate, 14
 - F-Traffic Config, 14
 - F-Traffic Format, 14
 - FULL (preset) key, 76
- G**
- gotolink SEL, 6
 - GPIO Address, 79
- H**
- Handoff, 27
 - Handoff Cell Band, 34
 - Handoff Channel, 34
 - Hardware ID (Decimal), 29
 - Hardware ID (Hex), 29
 - Hardware ID Type (Hex), 29
 - H-ARQ Modulation, 28
 - H-ARQ/L-ARQ Channel Level, 28
- I**
- Idle State, 28
 - Initiate Measurements, 54
 - Instrument Information
 - Test Application, 80
 - IntRef, 82
- L**
- LAN IP Address, 79
 - Last Calibration, 11
 - Limited TAP, GPIO Command, 14
- M**
- MAC Index, 37
 - Magnitude Error, 45
 - Maskable Message Display State, 40, 79
 - Max Forward Packet Duration, 14
 - Max Frames Allowed for
 - Assignment, 19, 23
 - MCC, 28
 - Meas Frequency, 57
 - Measurement Frequency, 57
 - Measurement Frequency Control, 57
 - MEASUREMENT RESET key, 81
 - Measurement Speed
 - Channel Power, 66
 - Measurement Timeout
 - Access Probe Power, 61
 - audio analyzer, 60
 - Channel Power, 65, 66
 - Digital Average Power, 68, 70
 - Graphical Access Probe Power, 70
 - Swept Audio, 72
 - TX Spurious Emissions, 67
 - Message Log, 81
 - Missing Bursts, 19, 23
 - Mobile Country Code, 28
 - Multi-Measurement Count
 - audio analyzer, 59
 - Channel Power, 65, 66
 - Digital Average Power, 68
 - Swept Audio, 71
 - TX Spurious Emissions, 67
- N**
- Number
 - amplitude offset, 80
 - Number of Points, 71
- O**
- Offset (dB)
 - amplitude offset, 80
 - Open Loop Adjust, 13
 - Operating Mode, 32
- P**
- Packet Error Count, 43
 - Packet Error Rate Confidence
 - Level, 64
 - Packet Error Rate Confidence
 - Pass/Fail, 43
 - Packet Error Rate Integrity, 43
 - Packet Error Rate Maximum
 - Packet Count, 64
 - Packet Error Rate Measurement
 - Results, 43
 - Packet Error Rate Requirement, 64
 - Packet Loss, 25
 - Packets Received, 25
 - Packets Tested, 43
 - Packets Transmitted, 25
 - Pages, 19, 23
 - P-ARQ Channel Level, 28
 - Phase Error, 45
 - Pilot Drop, 29
 - Ping, 25
 - Ping Count, 25
 - Ping Setup
 - Alternate Ping Address, 25
 - Device to Ping, 25
 - Ping Count, 25
 - Ping Timeout, 25
 - Ping Timeout, 25
 - Ping Timeout, 25
 - PN Offset, 33
 - power control
 - reverse link, 18
 - reverse link step size, 18
 - Power Parameters, T2P
 - Transition, 30
 - Power Parameters, Termination
 - Target, 30
 - Power Parameters, TxT2P
 - Post-Transition, 30
 - Power Parameters, TxT2P
 - Pre-Transition, 30
 - Preamble Length, 13
 - Preferred Control Channel Cycle, 17
 - Preferred Control Channel Cycle
 - Mode, 18
 - PRESET key, 76
 - Probe Initial Adjust, 13
 - Probe Num Step, 13
 - Probe Power Step, 13
 - Probe Sequence Max, 13
 - Protocol Logging, 32
 - Protocol Rev, 33
 - Pulse, 10
 - Pwr Ctrl Size, 18
- R**
- RACHs, 19, 23
 - Rate 1M8 Supported Control, 18
 - Rev Power Ctrl, 57
 - Read Measurement, 56
 - Receiver Power, 57
 - Receiver Power Control, 57
 - Register recall hardkey, 82
 - Release A Access Channel MAC
 - Subtype, 33
 - Release A Physical Layer
 - Subtype, 33
 - Rev, License, 78
 - reverse power control, 18
 - RF Gen Freq Ctrl, 18
 - RF Generator Frequency, 34
 - RF IN/OUT Amplitude Offset
 - State, 80
 - RF IN/OUT Amptd Offset, 80
 - RF IN/OUT Amptd Offset Setup, 80
 - RF Output Port, 58
 - Rho, 45
 - Round Trip (ms) min/avg/max, 25
 - RPC Channel Level, 28
 - RRI Gain Parameters, 29
 - RTAP Rate, 14

Index

Rvs Power Ctrl, 18

S

SAVE hardkey, 82
Sector ID, 32
Session Application Type, 14
Session Open State, 35
Session Seed, 29
Short Packets Enabled Threshold,
14
SINAD, 42
Swept Audio, 50
SINAD/Distortion Fundamental
Frequency
audio analyzer, 60
SINAD/Distortion State, 72
audio analyzer, 60
Single, 59
Slots to Measure, 69
Start Data Connection, 27
Start Frequency, 71
Start Ping, 25
step size
reverse link power control, 18
Stop Frequency, 71
Stop Ping, 25
Subnet Mask, 32, 79
Summary Results
Packet Loss, 25
Packets Received, 25
Packets Transmitted, 25
Round Trip (ms) min/avg/max,
25
Swept Audio, 50

T

Test Application (instrument
information), 80
Test Application Protocol, 14
Test Mode Forward Traffic Rate,
38
Test mode MAC Index, 38
Test Signal, 39
Thermal Power Null Adjust, 81
Time (hh.mm), 82
Time Error, 45
Time Zone (hh.mm), 83
Total RF Power, 37, 39
Total RF Power State, 37
Trigger, 39
Trigger Arm, 59
Access Probe Power, 61
audio analyzer, 59
Channel Power, 65, 66
Digital Average Power, 68, 70
Graphical Access Probe Power,
70

Swept Audio, 71
TX Spurious Emissions, 67
TX Spurious Emissions, 44

U

UATI 24, 37
UATI Color Code, 37
Universal Coordinated Time
(UTC), 83
Universal Coordinated Time
(UTC) Date, 83
Uplink Frequency, 57

W

Waveform Quality + Code
Domain, 45